

ONE STOP SMART PACKING SOLUTION

- Multi-head combination weigher
- Long-cut spaghetti/stick noodle weighting and packing line
- Linear weigher and automatic packing line
- Horizontal film forming, filling and sealing machine (HFFS)
- Vertical film forming, filling and sealing machine (VFFS)
- Vertical pre-made bag filling and sealing machine (VBFS)
- Powder, grain, liquid quantitative and packing line
- Powder, grain, liquid quantitative and canning line
- High speed cartoning machine
- Liquid filling and packing machine
- Hardware (Screw, nut...) Quantity counting and packing line
- Glove packing line
- Customized packing system
- Automatic carton packing line
- On-line metal detection machine
- On-line checking weigher

微型组合秤 Mini multihead weigher



JY-S10



JY-S14



主要特征Main features

- 微型组合秤专为小重量物料设计，提高速度和精准度；
- 可根据立式机结构，配套设计微型组合秤和立式机组成一体机，为客户节省空间和成本；
- 鸭嘴形伺服集料斗，很好的把物料集中到一个点填充以达到高速要求；
- 显示器中自带有帮助菜单，方便学习使用；
- 运行中各线振幅可单独设置；
- 原始预置参数配方操作更简便，配方可任意选择保存路径，名称和图案；
- 称重式物料检测，准确控制加料时间；
- 称重方式或者数粒均可实现；
- 称重斗可依次下料防止物料破损及堆叠。

Suitable for small weight packing, such as: seeds, beans, rice, white sugar, chocolate, medicine, green tea...

Features:

1. High-precision digital loadcell.
2. User-friendly help menu in touch screen help user easy operation.
3. No products auto pause function improve weighing stability and accuracy.
4. 50 programs preset capacity can meet various weighing requirements.
6. Multi-languages available for different markets.
7. Linear amplitude can be adjusted independently.
8. Weighing/counting function can be chosed to use according to real need.

主要参数/Specifications:

型 号 Model	JY-S10	JY-S14
头 数 Weigh head	10	14
称重范围 Weigh Range	10-200g	10-300g
最大速度 Max.Speed	60bpm/min	120bpm/min
精 度 Accuracy	±0.1-1.0g	±0.1-0.8g
功 率 Power Supply	1.5kw	2.0kw
包装尺寸 Packing Size	1000L*1000W*1000Hmm	1200L*1200W*1200Hmm
净重/毛重 N/G Weight	200/250kg	250/300kg
称 量 斗 Weigh Bucket	0.8L	
控 制 屏 Control Penal	9.7寸触摸屏 9.7" Touch Screen	
电 压 Voltage	单相电	Single Phase;220V/50HZ or60HZ
驱动系统 Drive System	步进电机	Stepper Motor(Modular Driving)

10头光斗组合秤

10 heads multihead weigher with smooth buckets



JY-10HST

使用范围/Use range

食品:零食,糖果,沙糖,豆,薯片,冷冻食品,沙拉,宠物食品等等。
非食品:小螺丝,纽扣,螺丝钉,玩具等等。
Food:Snack,candy,sugar,beans,chips,frozen food,salad,pet food...
Non food:small screws,the buttons,nails,toys

主要特征Main features

1. 电脑计算出最佳最精确的称重组合。
2. 称重斗可依次下料防止物料破损及堆叠。
3. 显示屏背光灯的亮灯时间可以手动调节。
4. 可与单台包装机配套使用。
5. 即时料斗振动指数方便更好的控制。
6. 50种物料的预设功能。
7. 线性振幅可以单独设置。
8. 模板化电机驱动,方便拆卸。



- 1) Auto choose the most efficient and accurate weight combination by computer .
- 2) Circle dump avoid materials drops together to avoid break and pile up.
- 3) Adjustable backlight control for vision protection.
- 4) Compatible with single packaging machine for automatic weighing.
- 5) Instant hopper vibration index for better control.
- 6) 50 preset programs for multiple tasks.
- 7) Individual setting linear vibration amplitude.
- 8) Templated motor drive, convenient for dismantling.

10头花纹斗组合秤

10Heads multihead weigher with dimpled buckets



JY-10HDT

主要参数/Specifications:

显示屏 Screen	9.7寸彩色触摸屏 9.7 inch color touch screen
称重范围 Weight range:	8克-1500克/次 8g-1500g/dump
最大速度 Max speed	60包/分 60bags/min
称重精度 Weight accuracy	± 1g
称重斗容积 Hopper size	1.5L
操作语言 Operate language	中文, 英文, 法文, 西班牙文, 匈牙利文等 English, France, Spanish, Hungary...
驱动 Drive	步进电机 By step motor
动力 Power	1500W
电压 voltage	110V, 220V, 50/60HZ
净重/毛重 Net/gross weight	260kg/330kg
机器尺寸 Machine size	95x95x100cm
包装尺寸 Packing size	108X108X124cm

10头双开门光面斗组合秤

10 Heads multihead weigher with double door smooth buckets



JY-10HDST

使用范围/Use range

食品:薯片,锅巴,宠物食品等膨化食品以及各类饼干,糖果,干果,中草药等干性物品。
非食品:小玩具,干燥剂,小五金件,小塑料件等
Food:chips, pet food, biscuit, candy, nuts, herb and other try products.
Non-food: small toy, dry desiccant, small metal piece, small plastic piece...

主要特征Main features

1. 电脑计算出最佳最精确的称重组合。
2. 称重斗可依次下料防止物料破损及堆叠。
3. 显示屏背光灯的亮灯时间可以手动调节。
4. 可与单台包装机配套使用。
5. 即时料斗振动指数方便更好的控制。
6. 50种物料的预设功能。
7. 线性振幅可以单独设置。
8. 模板化电机驱动,方便拆卸。



- 1) Auto choose the most efficient and accurate weight combination by computer .
- 2) Circle dump avoid materials drops together to avoid break and pile up.
- 3) Adjustable backlight control for vision protection.
- 4) Compatible with single packaging machine for automatic weighing.
- 5) Instant hopper vibration index for better control.
- 6) 50 preset programs for multiple tasks.
- 7) Individual setting linear vibration amplitude.
- 8) Templated motor drive, convenient for dismantling.

10头双开门花纹斗组合秤

10 Heads multihead weigher with double door dimpled buckets



JY-10HDDT

使用范围/Use range

冻虾,汤丸,饺子,贝壳类海鲜,QQ糖,葡萄干等其他粘性干果。
Frozen shrimp, dumpling,jiaozi,sea food,QQ soft candy,raisin and other sticky type fruits.

主要参数/Specifications:

称重范围 Weighing range	8-3000g
称量准确度 Accuracy	± 0.1-1g
最大速度 Max speed	60bags/min
电源要求 Power Supply	220V, 50/60HZ, 1.5KW
料斗容量 Hopper volume	2.5L
双开门料斗 Double doors hopper	2.5L
显示屏 Screen	9.7寸彩色触摸屏 9.7 inch color touch screen

14头光面斗组合秤

14 Heads multihead weigher with smooth buckets

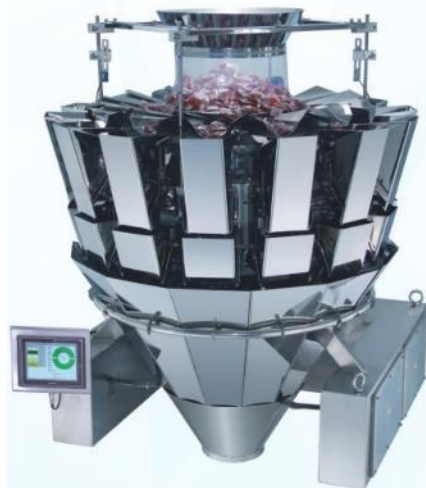

JY-14HST

主要特征Main features

- 1、电脑计算出最佳最精确的称重组合。
 - 2、称重斗可依次下料防止物料破损及堆叠。
 - 3、多语言的9.7英寸触摸屏。
 - 4、显示屏背光灯的亮灯时间可以手动调节。
 - 5、可与单台包装机配套使用。
 - 6、即时料斗振动指数方便更好的控制。
 - 7、50种物料的预设功能。
 - 8、线性振幅可以单独设置。
 - 9、模板化电机驱动,方便拆卸。
- 1) Auto choose the most efficient and accurate weight combination by computer .
 - 2) Circle dump avoid materials drops together to avoid break and pile up.
 - 3) 9.7 inch touch screen with multiple languages.
 - 4) Adjustable backlight control for vision protection.
 - 5) Compatible with single packaging machine for automatic weighing.
 - 6) Instant hopper vibration index for better control.
 - 7) 50 preset programs for multiple tasks.
 - 8) Individual setting linear vibration amplitude.
 - 9) Templated motor drive, convenient for dismantling.

14头花纹斗组合秤

14 Heads multihead weigher with dimpled buckets



JY-14HDT

主要参数/Specifications:

单次称重范围 Each dump weighing range	8-3000g
组合容量 Combination capacity	Max 3000ml
最高速度 Max speed	120 bags/min
物料长度 Length of material	最长15厘米/Max 150mm
单袋误差 Each bag error	0.1-2g
称重精度 Weighing accuracy	± 0.1-1g
驱动模式 Mode of driving	步进电机/Step motor
斗的模式 Form of dipper	双排无记忆斗 Double-row non-memory dippers
预设功能 Preset function	最多50种/Max 50 choices
材质 Material	接触物料的全部是304不锈钢 The part contacting materials is made of 304 stainless steel
料位控制 Level control	光电式(通过型) Photo electricity (pass type)
电源 Power source	AC110/200/220V ± 10% 2KVA
机器尺寸 Dimension	130X125X140CM

14头双开门光斗组合秤

14 heads multihead Weigher with double door smooth buckets



JY-14HDST

主要特征Main features

1. 彩色触摸屏, 9.7英寸大;
 2. 多种操作语言可供选择;
 3. 14个2.5L双开门光面斗;
 4. 可预设50种物料的参数,下次使用调出来就可以了,不用再重新设置;
 5. 每路振机振幅强度可单独设置,单独的线路板控制;
 6. 模拟信号式的称重,可连电脑及打印机,及时了解机器的工作情况;
 7. 可设依次放料,减少易碎物料相互碰撞,除低物料的破损率;
 8. 如果物料比较均匀,可用数数的功能代替称重来达到某种物料需要以个数来包装的目的;
 9. 使用进口的主要元器件,稳定性强耐用时间长,故障率低;
 10. 可与提升机\包装机等配套使用来实现全自动化;
- 1) 9.7 inch color touch screen, nice to look at and easy to operate, can add client information inside to high-light the company image.
 - 2) 14pcs 2.5L weighing buckets, double door open.
 - 3) Can preset 50 kinds of different products information, easy to pick out to use next time.
 - 4) Can connect to the computer or printer, easy to know the working data of the machines.
 - 5) Can combined with the elevator or the packing machine to be a full automatic packing line.
 - 6) Can set the material to be discharged one by one, so that to avoid the easy break products to hit each other and break.
 - 7) If products are almost the same in size and weight, we can use the counting function instead of the weighing, so that each bag can be the same number in piece.
 - 8) Adopt the import parts for the machine, so that stable and less malfunction, long use life.
 - 9) Each vibration feeder can be individual to control.
 - 10) Optional part: timing hopper/collection gate.

14头双开门花纹斗组合秤

14 Heads multihead weigher with double door dimpled buckets



JY-14HDDT

主要参数/Specifications:

单次称重范围 Each dump weighing range	8-3000g
组合容量 Combination capacity	Max 3000ml
最高速度 Max speed	120 bags/min
物料长度 Length of material	最长15厘米/Max 150mm
单袋误差 Each bag error	0.1-2g
称重精度 Weighing accuracy	± 0.1-1g
驱动模式 Mode of driving	步进电机/Step motor
斗的模式 Form of dipper	双排无记忆斗 Double-row non-memory dippers
预设功能 Preset function	最多50种/Max 50 choices
材质 Material	接触物料的全部是304不锈钢 The part contacting materials is made of 304 stainless steel
料位控制 Level control	光电式(通过型) Photo electricity (pass type)
电源 Power source	AC110/200/220V ± 10% 2KVA
机器尺寸 Dimension	130X125X140CM

Long cut spaghetti / stick noodle weighting and packing solution

全自动往复立体袋包装机 (一拖一) 200g-1000g

FULLY AUTOMATIC RECIPROCATING THREE-DIMENSIONAL BAG PACKAGING MACHINE (ONE TO ONE) 200G-1000G



产品功能 PRODUCT FEATURES

把散装挂面等条状物，通过自动称量、提升、自动整理、输送、包装等过程，通过塑料包装膜包装成扁状或者立体形状的产品。

产品优势 PRODUCT ADVANTAGES

- ◆ 立体成型：采用手工制袋的原理，制袋后的成品立体感强，折痕不易回弹。
- ◆ 新型输送线，实现高速运行、不露面、入口不弹面、不卡面。
- ◆ 卷纸辊刹车系统力量均匀，不受膜大膜小的影响，采用自动对中挂纸辊，安装卷膜简单方便，减少卷膜的浪费。
- ◆ 采用万能制袋器，方便快速切换不同宽度的产品包装。
- ◆ 采用往复封刀设计，封口美观更平整且无褶皱、不偏版，可适用于≥8丝厚的膜。

技术参数 TECHNICAL PARAMETER

包装成品形状	扁平袋或立体袋	双通用
包装范围	200g-1000g	根据客户产品要求
挂面长度	200mm-240mm	根据客户产品要求
包装速度	10-20包/分钟 (速度可调)	根据克重与条形可调节
设备尺寸	长4.2m×宽3.2m×高1.6m	
电源	220V/50Hz	
功率	5KW	

全自动往复立体袋包装机 (一拖二) 200g-1000g

FULLY AUTOMATIC RECIPROCATING THREE-DIMENSIONAL BAG PACKAGING MACHINE (ONE TO TWO) 200G-1000G



产品功能 PRODUCT FEATURES

把散装挂面等条状物，通过自动称量、提升、自动整理、输送、包装等过程，通过塑料包装膜包装成扁状或者立体形状的产品。

产品优势 PRODUCT ADVANTAGES

- ◆ 立体成型：采用手工制袋的原理，制袋后的成品立体感强，折痕不易回弹。
- ◆ 新型输送线，实现高速运行、不露面、入口不弹面、不卡面。
- ◆ 卷纸辊刹车系统力量均匀，不受膜大膜小的影响，采用自动对中挂纸辊，安装卷膜简单方便，减少卷膜的浪费。
- ◆ 采用万能制袋器，方便快速切换不同宽度的产品包装。
- ◆ 采用往复封刀设计，封口美观更平整且无褶皱、不偏版，可适用于≥8丝厚的膜。

技术参数 TECHNICAL PARAMETER

包装成品形状	扁平袋或立体袋	双通用
包装范围	200g-1000g	根据客户产品要求
挂面长度	200mm-240mm	根据客户产品要求
包装速度	25-40包/分钟 (速度可调)	根据克重与条形可调节
设备尺寸	长5.1m×宽3.2m×高1.6m	
电源	220V/50Hz	
功率	5.5KW	

Long cut spaghetti / stick noodle weighting and packing solution

全自动往复立体袋包装机 (一拖三) 200g-1000g

FULLY AUTOMATIC RECIPROCATING THREE-DIMENSIONAL BAG PACKAGING MACHINE (ONE TO THREE) 200G-1000G



产品功能 PRODUCT FEATURES

把散装挂面等条状物，通过自动称量、提升、自动整理、输送、包装等过程，通过塑料包装膜包装成扁状或者立体形状的产品。

产品优势 PRODUCT ADVANTAGES

- ◆ 立体成型：采用手工制袋的原理，制袋后的成品立体感强，折痕不易回弹。
- ◆ 新型输送带，实现高速运行、不露面、入口不弹面、不卡面。
- ◆ 卷纸驱动系统力量均匀，不受模大小影响，采用自动对中挂纸程，安装简单方便，减少卷膜的浪费。
- ◆ 采用万能制袋器，方便快速切换不同宽度的产品包装。
- ◆ 采用往复横封刀设计，封口美观更平整且无褶皱，不偏版，可适用于≥8丝厚的膜。

技术参数 TECHNICAL PARAMETER

包装成品形状	扁平袋或立体袋	双通用
包装范围	200g-1000g	根据客户产品要求
封面长度	200mm-240mm	根据客户产品要求
包装速度	40-60包/分钟(速度可调)	根据克重与条形可调节
设备尺寸	长6.3m×宽3.2m×高1.6m	
电源	220V/50Hz	
功率	6.5KW	



全动手提袋大克重包装机 (手提袋版)

FULLY AUTOMATIC TOTE BAG HEAVY-DUTY PACKAGING MACHINE (TOTE BAG VERSION)

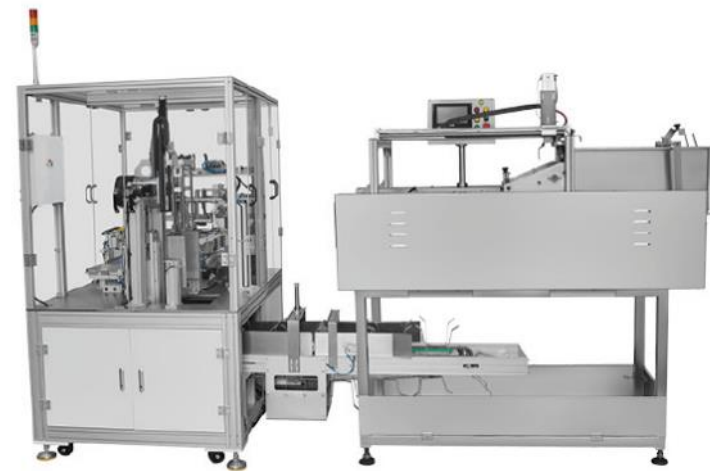

产品功能 PRODUCT FEATURES

把散装挂面、米粉、意大利面等条状物，经过自动称量、自动装手提袋、自动封口。

产品优势 PRODUCT ADVANTAGES

- ◆ 装面整齐不乱，采用仿手工袋原理；
- ◆ 包装美观，封口平整无褶皱，缩短袋膜长度，节约袋膜成本；
- ◆ 称量机采用新型直线导轨式料仓，可以有效的增加面条的配料整齐度，提高称量速度与精准度。



技术参数 TECHNICAL PARAMETER

包装成品形状	立体塑封袋	
包装范围	1.5kg-3kg	根据客户产品要求
产品长度	200-240mm (260mm 意面)	根据客户产品要求
包装速度	6-7包/分钟(速度可调)	根据重量与条形可调节
设备尺寸	长3.2m×宽2.2m×高1.9m	
电源	220V/50Hz	
功率	5KW	

Long cut spaghetti / stick noodle weighting and packing solution

全自动往复高速包装机 80g-300g (一拖四)

FULLY AUTOMATIC RECIPROCATING HIGH-SPEED PACKAGING MACHINE 80G-300G (ONE TO FOUR)



产品功能 PRODUCT FEATURES

把散装挂面等条状物，经过自动称量、提升、自动整理、输送、包装等过程，通过塑料包装膜包装成扁状的产品。

产品优势 PRODUCT ADVANTAGES

- ◆ 新型输送线，实现高速运行、不露面、入口不弹面、不卡面。
- ◆ 输送线出口加装新型齐面装置，保证面条整齐的进入到成型器。
- ◆ 采用往复式横封刀设计，封口美观更平整且无褶皱、不偏版，可适用于 $\geq 8-10$ 丝厚的膜。
- ◆ 采用自动对中挂纸辊，安装卷膜简单方便，减少卷膜的浪费。

技术参数 TECHNICAL PARAMETER

包装成品形状	扁平袋	
包装范围	80g-300g	根据客户产品要求
挂面长度	200-240mm	根据客户产品要求
包装速度	75-80包/分钟(速度可调)	根据重量与条形可调节
设备尺寸	长7.5m×宽3m×高1.6m	
电源	220V/50Hz	
功率	7.5KW	



新型自动称量捆扎机 50g-150g

FULLY AUTOMATIC ROTARY PACKAGING MACHINE 50G-150G



产品功能 PRODUCT FEATURES

把散装挂面、米粉、意大利面等条状物，经过自动称量，自动捆扎成圆柱型产品。

产品优势 PRODUCT ADVANTAGES

- ◆ 捆扎好的产品美观，捆扎带粘合长度长，捆扎牢固且不容易串动。
- ◆ 称量机采用新型直线导轨式料仓，可以有效的增加面条的理料整齐度，提高称量速度与精准度。
- ◆ 设备设有防护罩及接触食品部位都是不锈钢材质，保证食品安全、卫生、健康。

技术参数 TECHNICAL PARAMETER

包装成品形状	圆柱形	
单扎称重	50g-150g	根据客户产品要求
产品长度	200mm-240mm(260mm 意面)	根据客户产品要求
设备尺寸	长3.5m×宽1.15m×高1.35m	
电源	220V	
功率	2.3KW	



Long cut spaghetti / stick noodle weighting and packing solution

全自动往复立体袋捆扎联线包装机 (通用高端版) FULLY AUTOMATIC RECIPROCATING THREE-DIMENSIONAL BAG BUNDLING AND PACKAGING MACHINE (UNIVERSAL HIGH-END VERSION)



产品功能 PRODUCT FEATURES

把散装挂面、米粉、意大利面等条状物，经过自动称量、自动捆扎、自动提升、自动理料、自动计数排序、自动检测重量及剔除、自动搬运、自动输送、自动包装等过程，通过塑料包装膜包装成扁平袋、立体袋或者带托盘的高端产品。

产品优势 PRODUCT ADVANTAGES

- ◆ 立体成型：采用手工制袋的原理，制袋后的成品立体感强，折痕不易回弹。
- ◆ 采用往复式横封刀设计，封口折角美观平整且无褶皱、不偏版，可适用于纸塑复合膜与≥ 8-10 丝厚的膜。
- ◆ 卷纸辊刹车系统力量均匀，不受膜大膜小的影响采用自动对中挂纸辊，安装卷膜简单方便，减少卷膜的浪费。
- ◆ 精准计数、具有重量检测剔除功能及防空包功能，可以有效的减少包材的浪费。
- ◆ 捆扎联线可根据产能需求进行捆扎机与称量机三称到十称不同数量的配比。

技术参数 TECHNICAL PARAMETER

包装成品形状	扁平袋或立体袋	双通用
单包称重	300g-1000g	根据客户产品要求
捆扎范围	80g-150g	根据客户产品要求
产品长度	200mm-240mm(260mm 侧面)	根据客户产品要求
捆扎机速度	≥ 20 扎 / 分钟	根据单包重量和条形确定
包装速度	10-45 包 / 分钟 (速度可调)	根据单包扎数与捆扎机台数确定
设备尺寸	具体根据捆扎机台数确定	
电 源	220V/50Hz	
功 率	具体根据捆扎机台数确定	

散面全自动上料输送机 BULK AUTOMATIC FEEDING CONVEYOR

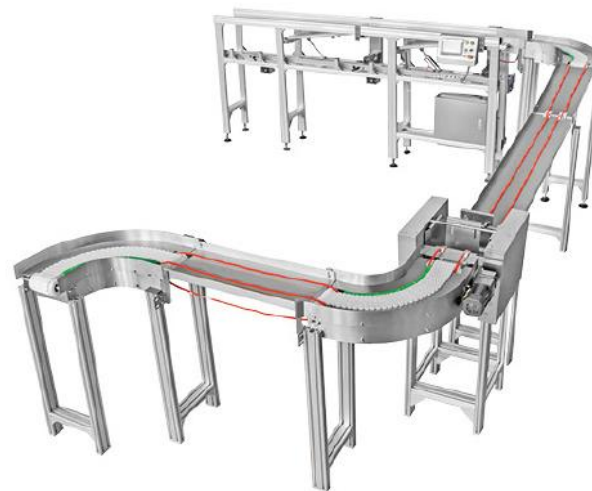

产品功能 PRODUCT FEATURES

把散面从切面机经过理料整齐、新型直线皮带输送、链板式转弯分料等过程，平稳整齐的输送到称量料仓里。

产品优势 PRODUCT ADVANTAGES

- ◆ 整体设计简洁明快，便于安装、维护及操作。
- ◆ 实现全自动无人化包装生产线，大大降低了人工成本，提高了生产效率。



链板式散面拐弯
自动整齐理料机



散面自动上料输送机



自动补料机械手

技术参数 TECHNICAL PARAMETER

输送挂面长度	180mm-300mm	根据客户产品要求
设备尺寸	2m×1m×1.5m	根据客户场地确定
电 源	220V	
功 率	根据实际方案确定	

ZX-C-4自动定量包装机

ZX-C-4 Automatic Quantitative Packaging Machine

适用范围 The Scope of Application

该包装机为智能称重式自动定量包装机，上下双层振动给料，四斗同时称重，精准快捷。主要包装小型颗粒状物料，如干果、炒货、瓜子、花生、蚕豆、鸡精、味精、杂粮、农药颗粒、小五金等。

ZX packaging machine is the intelligent weighing automatic quantitative packaging machine. The feeding system is designed in the mode of upper and lower double-deck vibration. This machine is controlled by computer and it is accurate and quick. Applicable to dried fruit, roasted seeds, melon seeds, peanut, broad beans, chicken essence, MSG, coarse cereals, pesticides (particles), hardware and other granular materials for packaging automation.



1. High-precision digital sensor makes the accurate measurement possible.
2. Microcomputer control system, modern techniques, easy operation, be dependable for use.
3. Multi-layer vibration feeding system, automatic error correction, memory the specifications of products, high precision packaging.
4. Multi scale alternating operation, pack quickly.
5. Adopt high quality 316 stainless steel, anticorrosive, dustproof, easy to clean.
6. Strong compatibility, easy to cooperate with other packaging devices.

主要参数 Main Parameter

型号 Model	包装范围 Range of packaging	包装速度 Packaging speed	包装精度 Packaging precision	功率范围 Power range	主机重量 Weight	主机外形尺寸 Overall dimension
ZX-C-4	20-2500克	1500-2500 袋/小时	±0.5%	220V/50HZ/750W	180公斤	950*930*2120(毫米) (长*宽*高)



性能特点 Performance Characteristics

1. 高精度数字式传感器使精确计量瞬间得以实现。
2. 微电脑控制系统，技术先进，操作简便，使用更可靠。
3. 多级振动给料，自动修正误差，具有产品规格记忆功能，实现高精度包装。
4. 多秤交替工作，极速包装。
5. 与物料接触部分采用优质304不锈钢，防腐防尘易清洗。
6. 兼容性强，易与其他包装设备配合使用。

单位(mm)

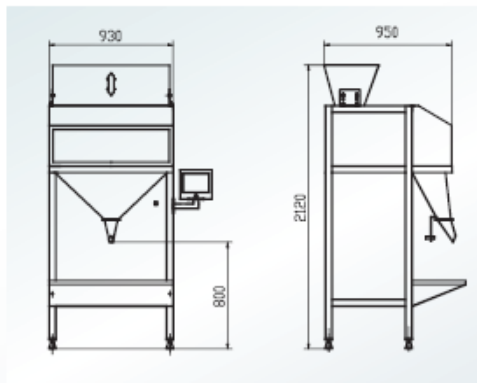

ZX-C-3颗粒定量包装机

ZX-C-3 Automatic Packaging Machine

适用范围 The Scope of Application

该包装机为智能称重式自动定量包装机，上下双层振动给料，气动直流，电脑控制，精准快捷。主要包装小型颗粒状物料，如干果、炒货、瓜子、花生、化工、鸡精、味精、杂粮、农药（颗粒）、小五金等。

ZX packaging machine is the intelligent weighing automatic quantitative packaging machine. The feeding system is designed in the mode of upper and lower double-deck vibration. This machine is controlled by computer with accurate and quick operation. Applicable to dried fruit, roasted seeds, melon seeds, peanut, broad beans, chicken essence, MSG, coarse cereals, pesticides (particles), hardware and other granular materials for packaging automation.

ZX-C-2颗粒定量包装机

ZX-C-2 Automatic Packaging Machine



主要参数 Main Parameter

型号 Model	包装范围 Range of packaging	包装速度 Packaging speed	包装精度 Packaging precision	功率范围 Power range	主机重量 Weight	主机外形尺寸 Overall dimension
ZX-C-2	1-10公斤	400-600 袋/小时	±0.5%	220V/50HZ/750W	260公斤	1350*910*2600(毫米) (长*宽*高)
ZX-C-3	1-5公斤	480-720 袋/小时	±0.5%	220V/50HZ/750W	300公斤	1450*850*2650(毫米) (长*宽*高)



性能特点 Performance Characteristics

1. 采用称重计量方式，精度高。
2. 双振动斗给料，双称重斗称重，气动直流，速度快。
3. 和物料接触部分采用优质304不锈钢，无污染。
4. 结构简单，拆卸清洗方便。
5. 采用触摸屏，具有规格记忆功能。

1. Use the weighing measurement method and has high precision.
2. It has dual vibration hopper to feed and dual weighing hopper to weigh. The speed is high.
3. The part contacting with materials uses the high-quality stainless steel without pollution.
4. The structure is simple and it is easy to disassemble and clean.
5. It has touch-screen and specifications memory function.

单位(mm)



自动灌装+封口+贴标流水线

Automatic Filling + Sealing And Pasting Assem Bly Line

适用范围 The Scope of Application

该流水线采用智能称量式自动定量包装机，有单秤、双秤、四秤。微电脑控制。适用于农药、化肥、兽药、预混料、添加剂、洗衣粉、食盐、味精、鸡精、白糖、种子、大米、休闲食品、小五金等颗粒状、粉状物料的定量包装。

The machine is intelligent weighing automatic quantitative packaging machine which has single, double and quadruple. Controlled by microcomputer. It applies to pesticide, fertilizer, animal medicine, premix, additive, washing powder, salt, MSG, chicken essence, sugar, seeds, rice, food, hardware, etc.



颗粒、粉剂（瓶装）流水线

Particles, Powder (bottled) lines



BZ-A-50自动定量包装机(颗粒\粉剂)

BZ-A-50 Automatic Quantitative Packaging Machine



单位 (mm)

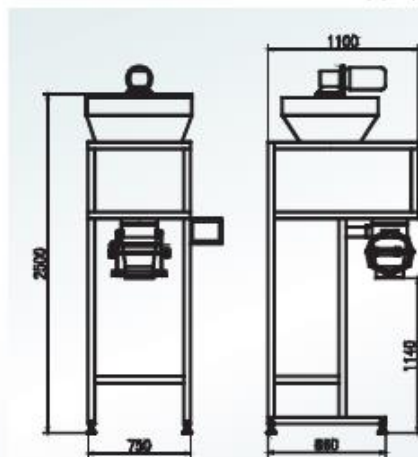

适用范围 The Scope of Application

适用于农药、化肥、涂料、面粉、可湿粉、橡胶粉、食品添加剂、颜料、染料等行业的粉剂定量包装。

It applies to the quantitative packaging of pesticides, fertilizers, paints, flour, wettable power, rubber power, food additive pigments dyes and other industrial power

性能特点 Performance Characteristics

1. 采用双螺旋送料，计量精度高，包装速度快，性能稳定，操作简单。
2. 采用精密控制仪表，可配带标准接口，高精度传感器，可实现与中央系统联接，对包装实时监控。
3. 料仓中有破拱装置，在螺旋输送前将物料打松散，从而使物料不易架拱。
4. 夹袋可选用手动或气动装置，包装时能将袋口密封，不会有粉尘溢出。
5. 与物料接触部件采用不锈钢材料和碳钢材料两种。
6. 可配套输送、缝包、封口装置。

1. Use the dual screw to feed. It has high measuring accuracy, packaging speed, stable performance and convenient operation.
2. Use the precision control device and high-precision sensors. Errors can be corrected automatically. The device can be equipped with the standard interface which can achieve the connection with the central system and implement real-time monitor for packaging.
3. The hopper has arch breaker device which can scatter the materials before screw conveyor so that the materials can be not arch breaking.
4. The clip bag device uses the manual or pneumatic device seal the mouth of the bag in packaging so that the dust will not overflow.
5. The parts contacting with the materials used the stainless steel material and carbon steel material.
6. Support transmitting and sewing, sealing device.

主要参数 Main Parameter

定量范围 Packaging specification	5-50公斤/袋
包装速度 Packaging speed	180-300袋/小时
包装精度 Packaging precision	±0.5%
整机功率 Complete machine power	1200W
电源电压 Power supply voltage	380V/50Hz
整机重量 Complete machine weight	280公斤
外形尺寸 Overall dimension	(长*宽*高)1100x750x2500(毫米)

ZX-D1型斗式输送机

ZX-D1 Type Bucket Conveyer



1. 适合颗粒物料的输送。与包装机配套使用可减轻劳动强度，提高劳动效率。
2. 可实现自动供料，自动停止，清洗方便。

ZX-D1

输送高度 Conveying herght	2100毫米 (高度可订做)	2600毫米 (高度可订做)
输送量 Conveying quantity	4立方米/小时 (可调)	10立方米/小时 (可调)
料仓容积 Hopper volume	0.1立方米	0.15立方米
外形尺寸 Overall dimension	(长*宽*高)2300×730×2600(毫米)	(长*宽*高)2500×1000×3100(毫米)

ZX-D2型斗式输送机

ZX-D2 Type Bucket Conveyer



ZX-D2

输送高度 Conveying herght	2100毫米 (高度可订做)	2600毫米 (高度可订做)
输送量 Conveying quantity	4立方米/小时 (可调)	10立方米/小时 (可调)
料仓容积 Hopper volume	0.1立方米	0.15立方米
外形尺寸 Overall dimension	(长*宽*高)2300×730×2600(毫米)	(长*宽*高)2500×1000×3100(毫米)

链板式上料机

Vertical Type Bucket Type Feeding Machine



输送高度 Conveying herght	2700毫米 (高度可订做)	2900毫米 (高度可订做)
输送量 Conveying quantity	10立方米/小时 (可调)	4-6立方米/小时 (可调)
料仓容积 Hopper volume	/	0.06立方米
外形尺寸 Overall dimension	(长*宽*高)3600×750×3200(毫米)	(长*宽*高)3300×650×3600(毫米)

ZX-Z型输送机

ZX-Z Type Conveyer



输送高度 Conveying herght	2700毫米 (高度可订做)	2900毫米 (高度可订做)
输送量 Conveying quantity	10立方米/小时 (可调)	4-6立方米/小时 (可调)
料仓容积 Hopper volume	/	0.06立方米
外形尺寸 Overall dimension	(长*宽*高)3600×750×3200(毫米)	(长*宽*高)3300×650×3600(毫米)

ZX-G1型自动定量液体灌装机

ZX-G1 Automatic Quantitative Liquid Filling Machine

该机器采用先进的计时常压定量灌装控制，精密电磁阀计量，四头灌装，无滴漏，无喷溅，无泡沫，抗腐蚀，是中小企业分装有毒，有腐蚀性，易挥发液体如农药（甲苯、二甲苯、液肥）、兽药（消毒液、口服液）、酒类等物料较为理想的灌装设备。



按材质可分为全不锈钢和聚乙烯两种
按工位可分为单面工位或双后各两工位

灌装规格 Filling specification	20-1000毫升/瓶
灌装速度 Filling speed	1200-2500瓶/时
灌装精度 Filling precision	±0.5-1.5%
外形尺寸 Overall dimension	(长*宽*高)750×500×1200(毫米)

BZ-AS型自动定量包装机

BZ-AS Automatic Quantitative Packing Machine

该机适用于化工、食品、农副产品等行业粉状物料的定量小包装。特别适合较重产品的定量包装。

1. 微电脑控制，参数可调整，误差可自动修正。
2. 使用方便，不受生产场地的限制。
3. 防腐性能好，不污染物料。



包装规格 Packaging specification	1-50克/袋
包装速度 Packaging speed	1200-2000袋/时
包装精度 Packaging precision	±0.2-0.5克
电源功率 Complete machine power	220V 300W
外形尺寸 Overall dimension	(长*宽*高)600×400×860(毫米)

ZX-T1型螺旋输送机

ZX-T1 Type Food For Screw Conveyer



适合粉剂物料的提升

1. 和包装机配套使用，可实现自动供料，自动停止。
2. 螺旋及料筒与料仓之间软连接，拆卸轻松。
3. 料筒下端有活门及正反反转开关，清洗方便。
4. 料仓加配震动电机，使物料自动进入螺旋。

输送高度 Conveying herght	1600毫米 (高度可订做)
输送量 Conveying quantity	1000-3000公斤/小时
料仓容积 Hopper volume	0.12立方米
外形尺寸 Overall dimension	(长*宽*高)1900×790×1950(毫米)

ZX-T2型螺旋输送机

ZX-T2 Type Food For Screw Conveyer



输送高度 Conveying herght	1600毫米 (高度可订做)
输送量 Conveying quantity	1000-3000公斤/小时
料仓容积 Hopper volume	0.12立方米
外形尺寸 Overall dimension	(长*宽*高)1900×790×1950(毫米)

YB-HS25 Horizontal packing machine (up film)

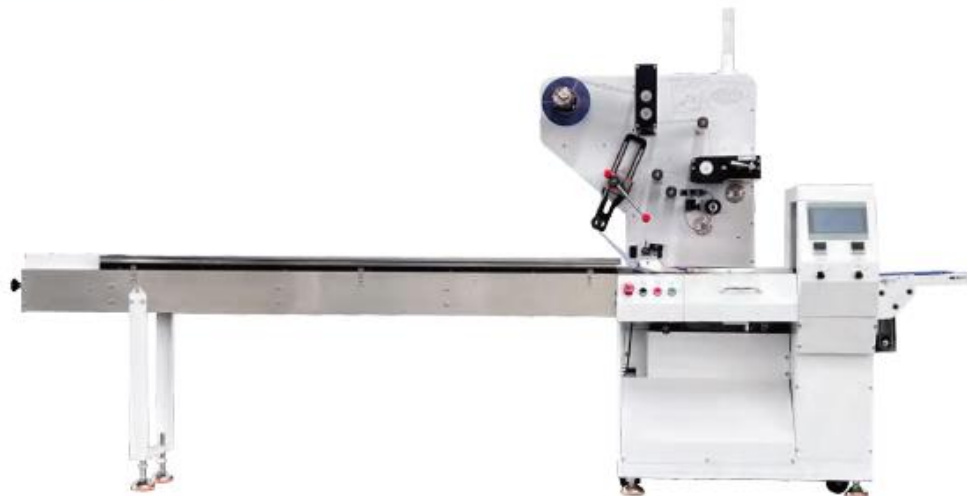

性能和特点 Features

1. 本公司独创有膜卷刹车机构,使走膜更稳定,消除膜卷外径变化的影响。
2. 配8道绕膜滚筒,走膜更加平稳,悬臂滚筒结构换膜更方便。
3. 拉膜滚筒配锥轮调速机构,可实现膜的前后速度完全一致。
4. 全新外观设计,机架用钢板焊接,稳重扎实有发光LOGO设计,可按客户需求更换。

1. The company has an original film roll brake mechanism, which makes the film run more stable and eliminates the influence of the change in the outer diameter of the film roll.
2. Equipped with 8 film-wrapping drums, the film run is more stable, and the cantilever drum structure is more convenient for film change.
3. The film-pulling drum is equipped with a cone wheel speed regulation mechanism, which can achieve the same speed before and after the film.
4. New appearance design, the frame is welded with steel plate, which is stable and solid. There is a luminous LOGO design, which can be replaced according to customer needs



技术参数 Technical parameters

Model 机型	Parameters 参数
Film width 薄膜宽度	Max.250mm
Packaging rate 包装速度	30-300bags/min
Bag length 制袋长度	65mm-更长longer
Bag width 制袋宽度	25-110mm
Product height 产品高度	Max.50mm
Power 电源规格	220V 50/60HZ 3.75KW (two knives双刀)
Machine weight 机器重量	400kg
Machine size 机器尺寸	(L)3400x(W)840x(H)1520mm

YB-HX35 Horizontal packing machine (down film)

性能和特点 Features

1. 三伺服电机配备PLC控制,独立温度PID控制,适应各种包装材质需求。
2. 人机界面简洁,参数设定方便,具备故障自诊断功能。所有控制由软件实现,便于调整和技术升级。
3. 采用高级光电眼色标跟踪技术,数字化输入封切位置,避免粘刀和浪费包装膜,自动感应物料长度,有产品时自动包装,无产品时自动停机等待,节省时间和膜料。
4. 传动系统采用链条传动,紧凑传动精度高,维护保养方便。
5. 机架采用焊接厚板一体成型,运行更稳定。外观使用闪光轿汽车钣金。

1. Three servo motors equipped with PLC control, independent temperature PID control, adapt to the needs of various packaging materials.
2. Simple man-machine interface, convenient parameter setting, with fault self-diagnosis function. All control is realized by software, easy to adjust and technology upgrade.
3. Adopting advanced photoelectric eye color-coded tracking technology, digitally inputting sealing and cutting position, avoiding sticking knife and wasting wrapping film, automatically sensing the length of the material, automatically packing when there are products and stopping and waiting when there are no products, saving time and film material.
4. The transmission system adopts chain drive, compact transmission precision, easy maintenance.
5. The frame is made of welded thick plate, more stable operation. Appearance using flash scale automobile sheet metal.

适用范围 Scope of application

适用于医药、日用品、五金、食品的包装
Suitable for medicine, daily necessities, hardware, food packaging

选配装置 Optional Devices

- | | |
|------------|---------------|
| 1. 打码机 | 2. 打孔机 |
| 3. 全不锈钢 | 4. 触摸屏 |
| 5. 充气装置 | 6. 排气装置 |
| 7. 无物料停机功能 | 8. 自定义封口图案或封纹 |
| 9. 自动进料装置 | 10. 自动收料装置 |
-
1. Date coder
 2. Automatic punching Device
 3. Full Stainless
 4. Touch Screen
 5. Air filling device
 6. Release the exhaust device
 7. No empty bag function
 8. Customized sealing patterns and notch
 9. Automatic feeder
 10. Automatic collection device



技术参数 Technical parameters

Model 机型	SK-HX25	SK-HX35	SK-HX45	SK-HX60
Film width 薄膜宽度	Max.250mm	Max.350mm	Max.450mm	Max.600mm
Packaging rate 包装速度	40-200bags/min	40-200bags/min	30-160bags/min	30-100bags/min
Bag length 制袋长度	65mm-更长longer	65mm-更长longer	100mm-更长longer	120mm-更长longer
Bag width 制袋宽度	30-110mm	50-160mm	50-180mm	100-280mm
Product height 产品高度	Max.50mm	Max.60mm	Max.80mm	Max.110mm
Power 电源规格	220V 50/60HZ 3.35KW	220V 50/60HZ 3.35KW	220V 50/60HZ 3.35KW	220V 50/60HZ 3.35KW
Machine weight 机器重量	560kg	560kg	700kg	750kg
Machine size 机器尺寸	(L)3592x(W)780x(H)1270mm	(L)3592x(W)880x(H)1270mm	(L)4000x(W)980x(H)1270mm	(L)4020x(W)1130x(H)1270mm

(注:制袋宽度指制袋宽度,产品高度指产品高度,制袋长度指制袋长度)



性能和特点 Features

1. 三伺服电机配备PLC控制, 独立温度PID控制, 适应各种包装材质需求。
2. 人机界面简洁, 参数设定方便, 具备故障自诊断功能。所有控制由软件实现, 便于调整和技术升级。
3. 采用高级光电眼色标跟踪技术, 数字化输入封切位置, 避免粘刀和浪费包膜, 自动感应物料长度, 有产品时自动包装, 无产品时自动停机等待, 节省时间和不浪费包装膜材料。
4. 传动系统采用皮带传动配合行星减速机, 紧凑传递精度高, 维护保养方便。
5. 双锥轮调速机构, 走膜控制更稳定。
6. 纵封采用大轮带加热盘, 配合烫板加热, 纵封双温控, 封合效果更美观稳定。
7. 机架采用焊接厚板一体成型, 运行更稳定, 机身全不锈钢材质。

1. Three servo motors equipped with PLC control, independent temperature PID control, adapt to the needs of various packaging materials.
2. Simple man-machine interface, convenient parameter setting, with fault self-diagnosis function. All control is realized by software, easy to adjust and technology upgrade.
3. Adopting advanced photoelectric eye color-coded tracking technology, digitally inputting sealing and cutting position, avoiding sticking knife and wasting wrapping film, automatically sensing the length of the material, automatically packing when there are products and stopping and waiting when there are no products, saving time and film material.
4. The transmission system adopts belt drive in combination with planetary reducer, which is compact with high transmission precision and easy to maintain.
5. Double cone wheel speed regulating mechanism, more stable control of film travelling.
6. The longitudinal sealing adopts a large wheel with heating disc, with the heating of the hot plate, the longitudinal sealing dual temperature control, sealing effect is more beautiful and stable.
7. The frame is made of welded thick plate, more stable operation, and the body is made of stainless steel.

技术参数 Technical parameters

Model 机型	SK-HS35	SK-HS45	SK-HS60
Film width 薄膜宽度	Max.350mm	Max.450mm	Max.600mm
Packaging rate 包装速度	40-60bags/min	30-60bags/min	20-60bags/min
Bag length 制袋长度	65mm-更长longer	65mm-更长longer	65mm-更长longer
Bag width 制袋宽度	50-160mm	50-210mm	100-280mm
Product height 产品高度	Max.60mm	Max.80mm	Max.80mm
Power 电源规格	220V 50/60HZ 4.15KW	220V 50/60HZ 4.15KW	220V 50/60HZ 4.15KW
Machine weight 机器重量	580kg	650kg	680kg
Machine size 机器尺寸	(L)4020x(W)770x(H)1450mm	(L)4020x(W)820x(H)1450mm	(L)4020x(W)920x(H)1460mm

适用范围 Scope of application

适用于医药、日用品、五金、食品的包装
Suitable for medicine, daily necessities, hardware, food packaging

选配装置 Optional Devices

- | | |
|-------------------------------|--|
| 1. 打码机 | 2. 打孔机 |
| 4. 全不锈钢 | 4. 触摸屏 |
| 5. 充气装置 | 6. 排气装置 |
| 7. 无物料停机功能 | 8. 自定封口图案或封纹 |
| 9. 自动进料装置 | 10. 自动收料装置 |
| 6. Release the exhaust device | 7. No empty bag function |
| 2. Automatic punching Device | 8. Customized sealing patterns and notch |
| 3. Full Stainless | 9. Automatic feeder |
| 4. Touch Screen | 10. Automatic collection device |
| 5. Air filling device | |



性能和特点

1. 三伺服电机配备PLC控制, 独立温度PID控制, 适应各种包装材质需求。
2. 人机界面简洁, 参数设定方便, 具备故障自诊断功能。所有控制由软件实现, 便于调整和技术升级。
3. 采用高级光电眼色标跟踪技术, 数字化输入封切位置, 避免粘刀和浪费包膜, 自动感应物料长度, 有产品时自动包装, 无产品时自动停机等待, 节省时间和膜料。
4. 传动系统采用皮带传动配合行星减速机, 紧凑传递精度高, 维护保养方便。
5. 双锥轮调速机构, 走膜控制更稳定。
6. 纵封采用大轮带加热盘, 配合烫板加热, 纵封双温控, 封合效果更美观稳定。
7. 机架采用焊接厚板一体成型, 运行更稳定, 机身全不锈钢材质。
8. 端封采用双滑轨凸轮机构, 机械切断机构使横封及切口更美观及密封性有保障。

Features

1. Three servo motors equipped with PLC control, independent temperature PID control, adapt to the needs of various packaging materials.
2. Simple man-machine interface, convenient parameter setting, with fault self-diagnosis function. All control is realized by software, easy to adjust and technology upgrade.
3. Adopting advanced photoelectric eye color-coded tracking technology, digitally inputting sealing and cutting position, avoiding sticking knife and wasting wrapping film, automatically sensing the length of the material, automatically packing when there are products and stopping and waiting when there are no products, saving time and film material.
4. The transmission system adopts belt drive with planetary reducer, which is compact with high transmission precision and easy maintenance.
5. Double cone wheel speed regulating mechanism, more stable control of film travelling.
6. Longitudinal sealing adopts large wheel with heating disc, with hot pole heating, longitudinal sealing double temperature control, sealing effect is more beautiful and stable.
7. The frame is made of welded thick plate, more stable operation, and the body is made of stainless steel.
8. The end seal adopts double-slide cam mechanism, and the mechanical cutting mechanism makes the cross seal and cut more beautiful and the sealing is guaranteed.



适用范围

适合与饼干, 米通, 雪饼, 面包, 方便面, 米粉, 日用品, 纸巾, 卫生巾, 工业零件, 纸盒或托盘等各类有规则物, 体带插角大包装。

Scope of application

Suitable for packing regular objects such as biscuits, pies, breadinstant, drugs, daily appliances, industrial parts, paper boxes, plates, etc.

技术参数 Technical parameters

Model 机型	SK-WS45	SK-WS60
Film width 膜宽	450mm	600mm
Bag length 袋长	120-450 mm	120-450mm
Bag width 袋宽	50-160mm	50-200mm
Product's height 最大产品高度	Max.140mm	max.140mm
Packing speed 包装速度	20-60bags/min	20-60bags/min
Power 电源	220V 50/60HZ 4.95KW	220V 50/60HZ 4.95KW
Machine dimension 机械尺寸	(L)4380x(W)870x(H)1000mm	(L)4380x(W)1230x(H)1660mm
Machine weight 机械重量	900kg	1200kg

YB-300F Pillow type four side seal packing machine

性能和特点 Features

- 1.六伺服系统控制,袋长即设即切,无需调节空走,一步到位,省时省膜。
- 2.人机界面,参数设定方便快捷。
- 3.故障自诊断功能,故障显示一目了然。
- 4.温度独立PID控制,更好适合各种包装材质。
- 5.定位停机功能,不粘刀,不浪费包膜。
- 6.传动系统简洁,工作更可靠,维护保养更方便。
- 7.所有控制由软件实现,方便功能调整和技术升级,永不落后。

1. Six servo system control, bag length is set to cut, no need to adjust the air away, one step in place, save time and
2. Human-machine interface, convenient parameter setting.
3. Failure self-diagnosis function, fault display at a glance.
4. Temperature independent PID control, better suited to a variety of packaging materials.
5. Positioning stop function, no sticking knife, no waste of wrapping film.
6. Simple transmission system, more reliable work, more convenient maintenance.
7. All controls are realized by software, which is convenient for function adjustment and technology upgrading, never lagging behind.



技术参数 Technical parameters

Model 机型	SK-300F
Film width 薄膜宽度	Max.220mm
Bag length 制袋长度	can be customized 根据产品定制
Bag width 制袋宽度	can be customized 根据产品定制
Product height 产品高度	can be customized 根据产品定制
Film roll diameter 膜卷直径	Max.350mm
Packing speed 包装速度	20~80bags/min
Powder 电源规格	220V, 50/60Hz, 10KW
Dimension 机器尺寸	(L)5100x(W)1000x(H)2030mm
Machine weight 机器重量	1500kg
Notes 备注	Optional: date printer 选配打码功能,可打印生产日期。



YB-BF Cling film packing machine

性能和特点 Features

- 1.操作性:采用人机界面参数交互模式,适用各种产品固定尺寸,兼容性较强。
- 2.稳定性:采用全伺服控制,减少机械摩擦,保证本机运转稳定,同时也降低维护成本。
- 3.外观:本机采用不锈钢样式,美观大方,便于清洗。

1. Operability: Adopting human-computer interface parameter interaction mode, applicable to a variety of products of fixed size, strong compatibility.
2. Stability: Adopt full servo control, reduce mechanical friction, ensure the stability of the machine operation, and also reduce maintenance costs.
3. Appearance: The machine adopts stainless steel style. It is beautiful and easy to clean.



技术参数 Technical parameters

Entry name 项目名称	Parameters 参数
Packing speed 包装速度	20-60bags/min
Film width 膜宽	220-550mm
Tray length 适用托盒长度	100-250mm
Tray width 适用托盒宽度	80-210mm
Tray height 适用托盒高度	18-60mm
Product height 物料高度	5-80mm
Power 整机功率	6KW
Dimension 整机尺寸	(L)3980(W)1030(H)1450mm

YBL Vertical packing machine (VFFS)

适用范围 Scope of application

适合要求计量精度高及易碎的散状物体的包装,如:膨化食品、锅巴、果冻、糖果、坚果类、苹果片、水饺、汤圆、巧克力、五金小件、药材等。

It is suitable for the packaging of bulk objects which require high precision of measurement and are fragile.

Such as: puffed food, rice crust, jelly, candy, nuts, apple slices, sweet dumplings, dumplings, chocolates, small hardware, herbs and so on.

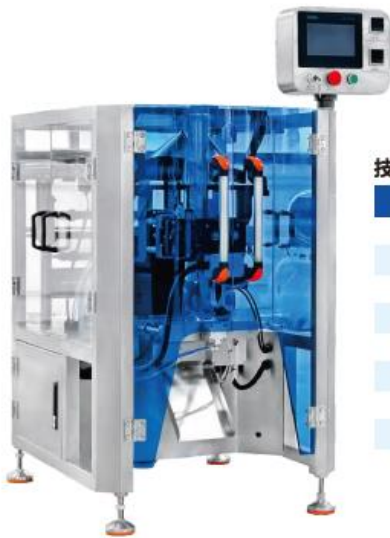

技术参数 Technical parameters

Model 机型	SKL-320	SKL-420
Bag length 制袋长度	40-200mm(L)	80-320mm(L)
Bag width 制袋宽度	50-150mm(W)	50-200mm(W)
Max width of roll film 薄膜宽度	320mm	420mm
Packing material 包装膜材质	OPP / CPP,OPP / PE,PET / PE	
Packing speed 包装速度	50-60bags/min	5-60bags/min
Measuring range 计量范围	150-1000ml	150-1500ml
Power voltage 电压	220V 50hz 2.2kw	220V 50/60hz 2.2kw
Machine weight 机械重量	300kg	500kg
Machine dimension 机械尺寸	(L)1500x(W)910x(H)1400mm	(L)1662 x(W)1170x(H)1410mm

技术参数 Technical parameters

Model 机型	SKL-520	SKL-720	SKL-820	SKL-1050
Bag length 制袋长度	80-420mm(L)	100-500mm(L)	100-550mm(L)	100-700mm(L)
Bag width 制袋宽度	80-250mm(W)	100-350mm(W)	180-400mm(W)	350-500mm(W)
Max width of roll film 薄膜宽度	520mm	720mm	820mm	1050mm
Packing material 包装膜材质	OPP / CPP,OPP / PE,PET / PE			
Packing speed 包装速度	5-50bags/min	5-40bags/min	5-30bags/min	5-15bags/min
Measuring range 计量范围	150-2000ml	500-3500ml	6000ml(Max)	6000-8500ml
Power voltage 电压	220V 50/60hz 2.5kw	220V50/60hz 3kw	220V 50/60hz 5kw	380V 50/60hz 3.2kw
Machine weight 机械重量	550kg	600kg	900kg	1150kg

Automatic vertical packing line

颗粒立式包装机 Granule vertical packing machine



包装样品/Packing samples

零食、干果、盐、糖、冷冻食品、坚果颗粒、五谷杂粮、宠物粮食、颗粒药物、植物种子、农化、日化用品、坚果、红枣枸杞、生鲜产品、膨化食品、五金、塑料等等。

Snacks, dried fruits, salt, sugar, frozen food, nut granules, whole grains, pet food, granular medicine, plant seeds, agrochemical, daily chemical products, nuts, red dates and wolfberry, fresh products, puffed food, hardware, plastics, etc.



粉末立式包装机 Powder vertical packing machine

包装样品/Packing samples

奶粉、洗衣粉、调味料、咖啡粉、可可粉、蛋白粉、面粉、木薯粉、茶粉、抹茶粉、食品粉、调味品、玉米粉、椰奶粉、芝麻粉、辣椒粉、各类粉末等

Milk powder, washing powder, seasoning, coffee powder, cocoa powder, protein powder, flour, tapioca powder, tea powder, matcha powder, food powder, seasoning powder, corn flour, coconut milk powder, all kinds of powder, etc



液体立式包装机 Liquid vertical packing machine



包装样品/Packing samples

洗衣液、饮料、原浆液、化妆液、酱料、宠物湿粮、果酱、番茄酱、洗涤剂、黄酒、酱油、米醋、果汁、饮料、花生酱、辣椒酱、豆瓣酱、各类液体等

Laundry detergent, beverage, raw slurry, cosmetic liquid, sauce, pet wet food, jam, ketchup, detergent, rice wine, soy sauce, rice vinegar, juice, beverage, peanut butter, chili sauce, bean paste, various liquids, etc



YBTB-120QY Liquid sachet packing machine



技术参数 Technical parameters

Model 设备机型	SKTB-120HY
Speed 包装速度	30-60bags/min
Bag Size 制袋尺寸	(length):40-170mm ; (width):20-50mm
Applicable film thickness 适用膜厚度	0.08mm-0.12mm , 最大卷膜直径MAX.320mm
Power 电机功率	2000W
packaging material 包装材料	Such as aluminium composite film OPP composite film, CPP composite film, etc. 如铝复合膜 OPP复合膜, CPP复合膜等
Noise 机器噪音	≤80dB
Measurement range 计量范围	5ml-20ml
Dimension 外形尺寸	(L) 1465X(W)870X(H)2000mm
Weight 整机重量	150Kg

性能和特点 Features

1. 中英文俄文显示屏控制系统, 全304不锈钢箱体, 只需在可显示的设置单元设定所需参数(袋长等)控制系统则自动优化匹配各动作配合, 从而达到最佳包装速度。
2. 双光源光电检测系统稳定可靠, 包装包装袋的商标完整。
3. 智能型温控仪控制, 自动完成计量、制袋、充填、封合、打印批号、切数及计数等全部工作。采用背封枕形袋封口形式。
4. 根据用户需要, 通过更换刀具可实现一字切断, 花纹切断一字形连带切断, 圆角切断, 使刀在切袋时平稳可靠不卡袋, 操作简单。

1. Control system with display in English, Chinese and Russian, all 304 stainless steel box, just set the required parameters (bag length, etc.) in the displayable setup unit and the control system will automatically optimise the matching of each action to achieve the best packing speed.
2. Dual source photoelectric detection system is stable and reliable, and the trademark of the packaging bag is complete.
3. Intelligent temperature controller control. Automatically complete all the work of metering, bag making, filling, sealing, printing batch number, cutting and counting. Adopt the form of back sealing pillow bag sealing.
4. According to user needs, one-word cutting can be realized by changing the tool. The pattern cutting is cut in a zigzag joint cutting, and the fillet corner cutting makes the knife stable and reliable when cutting the bag. It is easy to operate.

YBTB-120QF powder sachet packing machine



产品介绍:

中英文俄文显示屏控制系统, 全304不锈钢箱体, 只需在可显示的设置单元设定所需参数(袋长等)控制系统则自动优化匹配各动作配合, 从而达到最佳速度, 由PLC微电脑控制, 自动报警, 故障提示。采用人机界面操作系统, 自动显示装盒速度、数量、故障原因等性能参数, 采用自润滑系统运行更加平稳。机体采用优质不锈钢、与铝材结合。在同台设备中规定范围内可实现多规格的调整使用。手动和自动转换功能, 可配热熔胶机, 可按客户需求定制。

Product Introduction:

Chinese-English-Russian display control system, full 304 stainless steel box, just set the required parameters in the displayable setting unit (bag length, etc.) The control system will automatically optimise the matching of each action with each other so as to achieve the best speed, controlled by PLC micro-computer, with automatic alarms and fault prompts. Adopting man-machine interface operating system, automatically displaying the cartoning speed, quantity, cause of failure and other performance parameters, and adopting self-lubricating system for smoother operation. The body is made of high quality stainless steel, combined with aluminium. Adjustable use of multiple specifications can be realised within the specified range in the same machine. Manual and automatic conversion function, can be equipped with hot melt adhesive machine, can be customised according to customer needs.

技术参数 Technical parameters

Model 设备机型	SKTB-120QF
Speed 包装速度	30-60bags/min
Bag Size 制袋尺寸	(length):40-170mm ; (width):20-50mm
Applicable film thickness 适用膜厚度	0.08mm-0.12mm , 最大卷膜直径MAX.320mm
Power 电机功率	2000W
packaging material 包装材料	Such as aluminium composite film OPP composite film, CPP composite film, etc. 复合膜, 如: BOPP/PE, PET/PE, PET/AL等
Noise 机器噪音	≤80dB
Measurement range 计量范围	5ml-20ml
Dimension 外形尺寸	(L) 1000X(W)890X(H)1820mm
Weight 整机重量	200Kg

YBGD-200R premade bag packing machine



性能和特点

1. 全机不锈钢设计, 采用304不锈钢或者食品级塑料。
2. 全自动一体化完成上料, 计量, 给袋, 打码, 填充, 充气 (排气), 封口, 成品输出。
3. 人机界面, 触摸屏操作直观, 简便。
4. 智能调整, 若开袋失败, 后续工位不下料, 不封口, 避免浪费包材和原料。
5. 通过手柄可快速调整袋宽, 省事省工。
6. 适用更多的包装袋。自立袋、壶口袋、拉链袋等。可配备电子秤、粉末计量、液体计量, 实现全自动流水线包装。

Features

1. Stainless steel design, 304 stainless steel or food grade plastic.
2. Fully automatic integration to complete feeding, measuring, bag feeding, coding, filling, Air filling, (exhaust), sealing and finished product output.
3. Man-machine interface, touch screen operation is intuitive and easy.
4. Intelligent adjustment. If the opening bag fails, the subsequent stations do not feed or seal the bag, so that the bag material and raw material are no wasted.
5. The bag width can be adjusted quickly by the handle, saving time and labour.
6. Suitable for more bags, stand-up pouches, jug pockets, zip bags, etc. can be equipped with electronic scales, powder metering, liquid metering, to achieve fully automatic assembly line packaging.

技术参数 Technical parameters

Model 设备机型	SKGD-200R	SKGD-300R
No.Of working station 机械工位	Eight working station 八工位	
Bag type 包装袋类型	Gusseted bag, four sides sealing bag, fin seal bag, zip-lock bag, spout pouch bag, etc 自立袋、手提袋、四边封袋、拉链袋、三边封袋、壶嘴袋、纸袋等复合袋	
Bag size 包装袋尺寸	Bag width袋宽:80-200mm Bag length袋长:100-350mm	Bag width袋宽:180-300mm Bag length袋长:100-400mm
Packing speed 包装速度	20-60 bags/min (depends on the product weight) (其速度由产品本身及充填重量决定)	20-45 bags/min (depends on the product weight) (其速度由产品本身及充填重量决定)
Filling range 充填范围	10~2500g	10~3500g
Clapper width 机夹手宽度 (上袋宽)	The rocking wheel controls all stations to be adjusted together 摇轮控制所有工位一起调节	
Noise dB 噪音分贝	≤70分贝	
Sealing type 封口方式与尺寸	Straight+Mesh 直纹+网纹	
Machine weight 机器重量	1400KG	1800KG
Power 电源总功率	380V 3P 50/60HZ 3.5KW	380V 3P 50/60HZ 5.5KW
Air consume 压缩空气消耗量	≥0.6m ³ /min(customer provide 压缩空气由用户自行提供)	
Machine measure 外形尺寸	(L)2170mm(W)1540mm(H)1430mm	(L)2460mm(W)1870mm(H)1460mm

Exposed, all material contact parts made of 304 stainless steel; Transmission and support frames are steel
外露, 物料接触部分全304不锈钢, 传动及支撑机架全钢铁

YBGD-Automatic premade bag packing machine

颗粒给袋式包装机 Granule premade bag packaging machine



包装样品/Packing samples

零食、干果、盐、糖、冷冻食品、坚果颗粒、五谷杂粮、宠物粮食、颗粒药物、植物种子、农化、日化用品、坚果、红枣枸杞、生鲜产品、膨化食品、五金、塑料等等。

Snacks, dried fruits, salt, sugar, frozen food, nut granules, whole grains, pet food, granular medicine, plant seeds, agrochemical, daily chemical products, nuts, red dates and wolfberry, fresh products, puffed food, hardware, plastics, etc.



粉末给袋式包装机 Powder premade bag packaging machine



包装样品/Packing samples

奶粉、洗衣粉、调味料、咖啡粉、可可粉、蛋白粉、面粉、木薯粉、茶粉、抹茶粉、食品粉、调味粉、玉米粉、椰奶粉、芝麻粉、辣椒粉、各类粉末等

Milk powder, washing powder, seasoning, coffee powder, cocoa powder, protein powder, flour, tapioca powder, tea powder, matcha powder, food powder, seasoning powder, corn flour, coconut milk powder, sesame powder, chili powder, All kinds of powder, etc



液体给袋式包装机 Liquid premade bag packaging machine



包装样品/Packing samples

洗衣液、饮料、原浆液、化妆品、酱油、宠物湿粮、果酱、番茄酱、洗涤剂、黄酒、酱油、米醋、果汁、饮料、花生酱、辣椒酱、豆瓣酱、各类液体等

Laundry detergent, beverage, raw slurry, cosmetic liquid, sauce, pet wet food, jam, ketchup, detergent, rice wine, soy sauce, rice vinegar, juice, beverage, peanut butter, chili sauce, bean paste, various liquids, etc



YBL-420 2 in 1 packing machien



性能和特点 Features

占地小效率高: 紧凑设计节省空间, 速度20-60包/分钟, 适配中小到大批量生产。
 精准计量: 电子秤控制误差±0.1g, 减少原料浪费。
 稳定耐用: 高强度材料+精密工艺, 连续运行故障率低。
 智能控制: PLC系统自动调节参数, 适应颗粒类的多种物料。
 支持定制封口模具、打印格式。

Small footprint and high efficiency: compact design saves space, speed 20-60 bags/minute, suitable for small and medium to large-scale production
 Precise measurement: electronic scale control error $\pm 0.1g$, reducing raw material waste
 Stable and durable: high-strength materials + precision technology, low failure rate in continuous operation
 Intelligent control: PLC system automatically adjusts parameters to adapt to a variety of granular materials
 Support custom sealing mold and printing format

技术参数 Technical parameters

Model 机型	SKL-420
Bag length 制袋长度	80-320mm(L)
Bag width 制袋宽度	50-200mm(W)
Max width of roll film 薄膜宽度	420mm
Packing material 包装膜材质	OPP / CPP,OPP / PE,PET / PE
Packing speed 包装速度	20-60bags/min
Measuring range 计量范围	150-1500ml
Power voltage 电压	220V 50/60hz 2.2kw
Machine weight 机械重量	500kg

YBGD-6GW pre-made bag packing machine



技术参数 Technical parameters

Model 设备机型	SKGD-6GW
Speed 包装速度	20-60bags/min
Bag Size 制袋尺寸	(length) :140—300mm ; (width) :80—200mm
Bag type 包装袋类型	Flat bags, stand-up bags, zipper bags, tote bags, M bags (the equipment needs to be partially reformed) 平面袋、自立袋、拉链袋、手提袋、(后期增加及时更新)
Measurement range 计量范围	5-2500g
Dimension 外形尺寸	(L) 1140(W)1050(H)2500mm
Weight 整机重量	750kg
power 电源总功率	380 4p 50/60HZ 3KW

性能和特点 Features

精密稳定: 自主研发内凸轮传动系统, 运行噪音降低40%。
 紧凑设计: 1140mm超短机身, 整机自重超1吨, 小空间实现稳定生产。
 选配: 5种可选插件(开底袋/拉链袋/捅料等), 适配食品、日化等8大行业。

Precision and stability: self-developed internal cam drive system, reducing operating noise by 40% .
 Compact design: 1140mm ultra-short body, and the whole machine weighs more than 1 ton in a small space to achieve stable production

Optional: 5 optional plug-ins (open bottom bag/zipper bag/poke material, etc.), suitable for 8 major industries such as food industry,daily chemical industry.

YBZH-1990 high speed cartoning machine



YBZH-2620 automatic cartoning machine

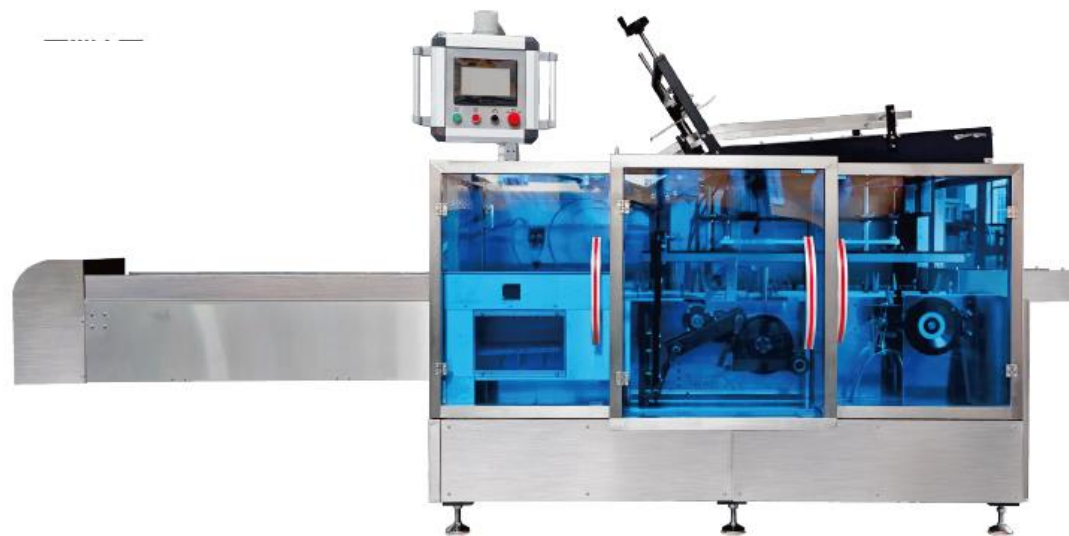

Hi Speed Cartoning machine

性能和特点 Features

1. 全自动吸盒、装盒、折盒成型的包装形式，结构紧凑合理，
2. 卧式机型，凸轮全机械联动，链条式单向传动。
3. 机型适用尺寸范围内，可进行快速调节换款。
4. 采用伺服/步进电机、触摸屏、PLC可编程控制系统。
5. 采用光电眼自动检测跟踪系统，空包不吸盒，最大限度地节省包装材料。

1. Full-automatic box suction, box loading, box folding and molding packaging form, compact and reasonable structure.
2. Horizontal model, cam full mechanical linkage, chain one-way transmission.
3. Model applicable size range, can be quickly adjusted to change models.
4. Adopt servo/stepping motor, touch screen, PLC programmable control system.
5. Adopting photoelectric eye automatic detection and tracking system, empty package does not suck box, maximize the saving of packaging materials.



技术参数 Technical parameters

Model 设备机型	SKZH-1990
Speed 包装速度	40-90Boxes/min
Box size 纸盒尺寸	Max:190x90x60mm (LxWxH) Min:80x20x15mm (LxWxH)
Box requirements 纸盒纸质要求	Gray card stock灰卡纸: 300-350g/m ³ White card stock白卡纸/: 250-350g/m ³
Total power 电源总功率	1.875KW (Main motor power 主电机功率:1.1KW)
Voltage 电源类型	220V-50HZ三相交流电源
Noise 机器噪音	≤80dB
Air sources 气源	0.5-0.8Mpa
Dimension 外形尺寸	(L)3316x(W)1230x(H)1884mm
Weight 整机重量	1500Kg

性能和特点 Features

1. 全自动吸盒、装盒、折盒成型的包装形式，结构紧凑合理，
2. 卧式机型，凸轮全机械联动，链条式单向传动。
3. 机型适用尺寸范围内，可进行快速调节换款。
4. 采用伺服/步进电机、触摸屏、PLC可编程控制系统。
5. 采用光电眼自动检测跟踪系统，空包不吸盒，最大限度地节省包装材料。

1. Full-automatic box suction, box loading, box folding and molding packaging form, compact and reasonable structure.
2. Horizontal model, cam full mechanical linkage, chain one-way transmission.
3. Model applicable size range, can be quickly adjusted to change models.
4. Adopt servo/stepping motor, touch screen, PLC programmable control system.
5. Adopting photoelectric eye automatic detection and tracking system, empty package does not suck box, maximize the saving of packaging materials.



技术参数 Technical parameters

Model 设备机型	SKZH-2620
Speed 包装速度	20-60Boxes/min
Box size 纸盒尺寸	Max:260x180x80mm (LxWxH) Min:90x30x20mm (LxWxH)
Box requirements 纸盒纸质要求	Gray card stock灰卡纸: 300-350g/m ³ White card stock白卡纸/: 250-350g/m ³
Total power 电源总功率	1.62KW (Main motor power 主电机功率:1.5KW)
Voltage 电源类型	220V-50HZ三相交流电源
Noise 机器噪音	≤80 dB
Air sources 气源	0.5-0.8 Mpa
Dimension 外形尺寸	(L)3825x(W)1592x(H)1761mm
Weight 整机重量	1000Kg

YB Automatic liquid filling machine

Automatic liquid filling machine



技术参数 Technical parameters

Model 机型	Parameters 参数
灌装范围/Filling range	100-1000ml/40-250bags/min
灌装速度 /Filing speed	<60-80 bottles/min (Base on500-2000ml)
计量精确度/Measurement accuracy	±1%
额定功率、电压 /Power	6.6KW. 380V
气源气压/Air pressure	0.6-0.7mpa
整机尺寸/Machine dimension	(L)3000(W)1500(H)2300mm
机器净重 /weight	950kg

性能和特点 Features

高效灌装:

1. 跟随式高速灌装采用传感器精准找瓶, 跟随式灌装, 生产过程无停顿。传统多头自动灌装价格昂贵, 生产过程瓶子须停顿, 灌装速度慢。
2. 跟随式高速灌装对不同形状、不同高度、不同容量的瓶子, 只需几分钟即可完成调试, 进入下一波生产, 彻底解决因种类繁多、单品数量少、频繁调机而费时费力的问题。传统自动灌装需反复调试才能重新投入生产, 费事费人工, 而且对部分异型瓶根本无法适用。

Efficient filling

1. Follow-type high-speed filling machine adopts sensor to accurately find bottles, follow-type filling, no pause in the production process. Traditional multi-head automatic filling machine is expensive, the production process of bottles must stop, filling speed is slow.
2. Follow the high-speed filling machine for different shapes, different heights, different capacities of bottles, only a few minutes to complete the debugging, into the next wave of production, a complete solution to the problem of time-consuming and laborious due to the variety, the number of single product is small, and frequent adjustments to the problem of time-consuming and laborious. Traditional automatic filling machines need to be repeatedly debugged to re-enter production, laborious and laborious, and for some shaped bottles can not be applied.

简要说明 Introduction

六头跟踪式灌装由链板输送机、夹瓶式自动对准机构、灌装机构、自动伺服跟随系统、电动升降调节机构、防水电柜、触摸式人机操作界面等组成, 能适用于不同规格瓶子的自动灌装设备。

The six-head tracking filling machine is composed of a chain plate conveyor, a bottle-clamping automatic alignment mechanism, a filling mechanism, an automatic servo following system, an electric lifting adjustment mechanism, a waterproof electric cabinet, and a touch-type man-machine operation interface. It can be applied to automatic filling equipment for bottles of different specifications.

产品特征 Feature

1. 采用世界知名品牌的电器和气动元件, 故障率低, 性能可靠, 使用寿命长
2. 采用高强度不锈钢框架, 拆装简便, 易清洗, 符合GMP要求
3. 灌装量和灌装速度调整简单, 由触摸屏操作和显示, 外形美观:
4. 设有无瓶不灌装功能, 液位自动控制加料;
5. 不需更换零件, 即可快速调整各种不同形状规格的瓶子:
6. 灌装头设有特殊防漏装置, 灌装无拉丝, 滴漏现象。



1. Using the world famous brand of electrical and pneumatic components, low failure rate, reliable performance, long service life.
2. Adopting high-strength stainless steel frame, easy to disassemble, easy to clean, in line with GMP requirements.
3. filling volume and filling speed adjustment is simple, by the touch screen operation and display, beautiful appearance;
4. It is equipped with the function of not filling without bottles, and the liquid level is automatically controlled for refilling;
5. Without replacing parts, it can quickly adjust various bottles of different shape and specification;
6. The filling head is equipped with special anti-leakage device, filling without pulling, dripping phenomenon.

YB Automatic powder canning machine



简要说明 Introduction

伺服及气动系统控制托罐及水平走罐，定位准、速度快。伺服马达及伺服驱动控制螺杆，性能稳定、精度高。全不锈钢结构，水平开启式料箱(里外抛光)，清洗十分方便。PLC控制、触摸屏人机界面显示，操作简便。高反应速度的称重系统、保证高罐装速度及高精度得以实现。充填头配有手轮调整高度，轻松实现多种罐型罐装。可配除尘装置，接负压管道，无粉尘污染环境。水平直线式结构，占地面积小，易于清洗。固定式螺杆安装结构，罐装时不产生金属污染。工作流程：进罐→托罐→振动→计量充填→称重反馈→检重→超差剔除→出罐。

Servo and pneumatic system control tank holder and horizontal can running, accurate positioning, fast speed. Servo motor and servo drive control screw, stable performance, high precision. All stainless steel structure; horizontal open type material box (inside and outside polishing), cleaning is very convenient. PLC control, touch screen man-machine interface display, easy to operate. High response speed weighing system, to ensure high canning speed and high precision to achieve. The filling head equipped with a hand wheel to adjust the height, easy to achieve a variety of tank type canning. Can be equipped with dust removal device, connected to negative pressure pipe, no dust pollution of the environment. Horizontal linear structure, small footprint, easy to clean. Fixed screw installation structure, no metal pollution is generated during canning. Workflow: tank entry → tank support → vibration → metering and filling → weighing feedback → weight check → over-difference rejection → tank exit.

技术参数 Technical parameters

Model 机型	Parameters 参数
容器尺寸 / Container size	φ30-160mm, H50-260mm 金属罐、玻璃罐、塑料罐、纸罐等 Meral cans, glass jars, plastic cans, paper canisters, etc.
灌装重量 / Filling weight	10-5000g (更换螺杆规格 Change screws specification)
灌装精度 / Filling Accuracy	100-500g, ≤ ±1g; >500g, ≤ ±2g
灌装速度 / Filling Speed	20罐/分钟 20cans/min (#502), 35罐/分钟 35cans/min (#300-#401)
电源 / Power, voltage	3P AC208-415V 50/60Hz
压缩空气 / Air supply	6kg/cm ² 0.2cbm/min
整机功率 / Total Power	3.4KW
整机重量 / Total Weight	1000kg
整机尺寸 / Dimension of the whole machine	(L)3000(W)1200(H)2100mm
料箱容积 / Hopper Volume	50L

YB multi-head liquid canning machine



简要说明 Introduction

适用于不同规格容器的灌装，可在数分钟内切换灌装规格，灌装周期短。操作程序、灌装方式等，画面直观、操作简单、维护方便。每个灌装头设有防漏功能。各种形状的容器，都能在设备中有效灌装。选用国际先进的气体灌装阀，确保灌装过程无滴漏、无垂涎，强大的PLC软件支持，可实现理想的灌装作业。人机界面，所有操作均在触摸式彩屏上完成灌装采用，固定流量参数控制灌装时间，来实现不同计量的灌装。气动阀灌装的精确时间设定到0.01秒处佳，。进瓶技术程序，无瓶、计数不到位不灌装，只有当计数器记录到的瓶数与设定的灌装瓶数一致时才开始灌装。灌装量的多少，可以进行初调到所需灌装量时，再进行微调，即可得到理想的灌装计量精度。注：灌装范围和速度可依据用户需求来设计不同的灌装头数。

Applicable to the filling of containers of different specifications, can be switched within a few minutes filling specifications, filling cycle is short. The operation program and filling method are intuitive, simple to operate and easy to maintain. Each filling head is equipped with a leak-proof function. Various shapes of containers can be effectively filled in the equipment. Selection of international advanced gas filling valve, to ensure that the filling process without dripping, no drooling, strong PLC software support, can realize the ideal filling operation. Man-machine interface, all operations are completed in the touch color screen filling adopted, fixed flow parameters to control the filling time, to achieve the filling of different measurements. Pneumatic valve filling of the precise time set to 0.01 seconds at the best. Into the bottle technology program, no bottle, counting is not in place not to fill, only when the counter recorded to the number of bottles and set the number of bottles to be filled consistent with the start of filling. The amount of filling can be initially adjusted to the desired amount of filling, and then fine-tuned to get the ideal filling metering accuracy. Note: The filling range and speed can be designed according to the user's demand for different number of filling heads.

技术参数 Technical parameters

Model 机型	Parameters 参数
灌装范围 / Filling range	50~1000ml
灌装速度 / Filling Speed	<60瓶/分钟 (指100~500毫升范围) <60bottles/min (Base on 100 ~ 500ml)
计量精确 / Measurement accuracy	± 1%
额定功率、电压 / Power, voltage	1.5KW. 220V
工作气压 / Working air pressure	6~7kg/cm ²
耗气量 / Gas consumption	0.8-1m ³ /min
机器净重 / weight	600kg

单盘螺丝 振动盘包装机

Single Vibrating Plate
Plate packing machine



双盘螺丝 振动盘包装机

Double Vibrating Plate
Packing Machine



三盘螺丝 振动盘包装机

Three Vibrating Plate
Packing Machine



十盘螺丝振动盘包装机

Ten Vibrating Plate Packing Machine



性能和特点 Features

1. 针对物料样品量身定做的振动盘, 直线振动排列装置, 精密的计数控制装置, 确保每袋准确无误。
2. 电控采用PLC控制系统, 并设中英文人机界面, 调整方便, 自动化程度高, 适用于单种物料包装和多种物料的混合包装。
3. 采用智能型温控仪双路控制, 纵封, 从而使封口牢固, 密封性好, 袋形平整。
4. 制袋系统采用步进电机细分技术, 自动跟踪、定位包装袋的色标(选配), 轻松完成制袋的动作, 调整速度快, 运行平稳, 噪音低。
5. 设备封口牢固、密封性好、袋形平整、精美, 包装效率高坚固耐用, 可加装有振动盘机玻璃护罩、排气装置、打码机(选配)、成品输送带(选配)
6. 设备能实现对物料自动排列、自动计数、装包、打印生产批号等工作。螺丝包装颗数随意调节, 袋数可自行控制, 可设定需要包数, 达到数量时自动停机。自动统计包装数量, 可方便地统计出机器的工作量。
7. 设备具有无料、缺料自动检测, 缺料、无料时设备会自动停机报警, 设备中每个振动盘可任意开启或关闭, 以方便生产需要。
8. 设备具有可靠的安全防护功能(各危险部位均安装有安全防护装置)

1. Tailor-made vibrating plate for material samples, linear vibration arrangement device, precise counting control device to ensure the accuracy of each bag.
2. The electric control adopts PLC control system, and set up Chinese and English human-machine interface, easy to adjust, high degree of automation, suitable for single material packaging and a variety of materials mixed packaging.
3. Intelligent temperature controller adopts dual-channel control of horizontal and vertical sealing, which makes the sealing firm, good sealing and flat bag shape.
4. The bag-making system adopts stepping motor subdivision technology, automatically tracking and positioning the color code of the bag (optional), easily completing the bag-making action, fast adjustment speed, smooth operation and low noise.
5. equipment sealing firm, good sealing, bag shape flat, exquisite, high packaging efficiency and durable, can be added with vibrating plate machine glass shroud, exhaust device, coding machine (optional), finished product conveyor belt (optional)
6. equipment to achieve the automatic arrangement of the material, automatic counting, bagging, printing the production batch number and other work. The number of screws packaged can be adjusted at will, the number of bags can be controlled by yourself, the number of packages can be set, and the machine will stop automatically when the number is reached. Automatic counting the number of packages, can easily count the workload of the machine.
7. The equipment has no material, lack of material automatic detection, lack of material, no material when the equipment will automatically shut down the alarm, each vibration plate in the equipment can be opened or closed at will, to facilitate production needs.
8. The equipment has reliable safety protection function (each dangerous part is installed with safety protection device).

技术参数 Technical parameters

Entry name 项目名称	Parameters 参数	Parameters 参数	Parameters 参数
type 型号	SKL-320 series (Single Vibrating Plate 单盘)	SKL-320 series (Double Vibrating Plate 双盘)	SKL-320 series (Three Vibrating Plate 三盘)
Voltage 电压	220V/50HZ	220V/50HZ	220V/50HZ
Power 功率	2.0KW	2.0KW	3.5KW
Air consumption 耗气量	0.4-0.6MPa	0.4-0.6MPa	0.4-0.6MPa
Bag size 袋子尺寸	L:50-140mm W:40-140mm (can be customized)		
Bag type 袋型	3 sides sealing bag back side sealing		
Packing speed 包装速度	10-60 bags/min	10-60 bags/min	10-40 bags/min
Measurement range 计量范围	1-20 grains (customizable on request)		
Dimension 外形尺寸	(L)1100(W)700(H)1600mm	(L)1100(W)700(H)1600mm	(L)1100(W)700(H)1600mm
Machine weight 整机重量	200kg	400kg	400kg

YB-HX45 Rob ice pillow packing machine



性能和特点 Features

1. 三伺服电机配备PLC控制, 独立温度PID控制, 适应各种包装材质需求。
2. 人机界面简洁, 参数设定方便, 具备故障自诊断功能。所有控制由软件实现, 便于调整和技术升级。
3. 采用高级光电眼色标跟踪技术, 数字化输入封口位置, 避免粘刀和浪费包膜, 自动感应物料长度, 有产品时自动包装, 无产品时自动停机等待, 节省时间和膜料。
4. 传动系统采用同步带结构, 紧凑传递精度高, 维护保养方便。
5. 可调式承袋器采用全铜材质的滑板, 尺寸调节更精准。
6. 单悬臂结构设计, 并设有刀座定位槽, 更换刀座无需调节。
7. 机架采用焊接厚板一体成型, 运行更稳定, 机身全不锈钢材质。
1. Three servo motors equipped with PLC control, independent temperature PID control, adapt to the needs of various packaging materials.
2. Simple man-machine interface, convenient parameter setting, with fault self-diagnosis function. All control is realized by software, easy to adjust and technology upgrade.
3. Adopting advanced photoelectric eye color-coded tracking technology, digitally inputting sealing and cutting position, avoiding sticking knife and wasting wrapping film, automatically sensing the length of the material, automatically packing when there are products and stopping and waiting when there are no products, saving time and film material.
4. The transmission system adopts synchronous belt structure, high precision of compact transmission and easy maintenance.
5. Adjustable bag carrier adopts full copper material slide plate, the size adjustment is more accurate.
6. Single cantilever structure design, and equipped with knife seat positioning slot, replacement of knife seat without adjustment.
7. The frame is made of welded thick plate, more stable operation, and the body is made of stainless steel.

技术参数 Technical parameters

Model 机型	SK-HX45
Film width 薄膜宽度	Max.450mm
Bag length 制袋长度	100mm-更长longer
Bag width 制袋宽度	50-180mm(根据产品厚度决定)
Product height 产品高度	Max.75mm(可以定制)
Packing speed 包装速度	15-45bags/min
Powder 电源规格	220V, 50/60Hz, 5.5KW
Dimension 机器尺寸	(L)6930x(W)2025x(H)1430mm
Machine weight 机器重量	1100kg



适用范围 Scope of application

适用于医药、日用品、五金、食品的包装

选配装置 Optional Devices

- | | |
|------------|---------------|
| 1. 打码机 | 2. 打孔机 |
| 3. 全不锈钢 | 4. 触摸屏 |
| 5. 充气装置 | 6. 排气装置 |
| 7. 无物料停机功能 | 8. 自定义封口图案或封纹 |
| 9. 自动进料装置 | 10. 自动收料装置 |
1. Date coder
 2. Automatic punching Device
 3. Full Stainless
 4. Touch Screen
 5. Air filling device
 6. Release the exhaust device
 7. No empty bag function
 8. Customized sealing patterns and notch
 9. Automatic feeder
 10. Automatic collection device

YB-HX35 pillow packing machine for screw

性能和特点 Features

1. 三伺服电机配备PLC控制, 独立温度PID控制, 适应各种包装材质需求。
2. 人机界面简洁, 参数设定方便, 具备故障自诊断功能。所有控制由软件实现, 便于调整和技术升级。
3. 采用高级光电眼色标跟踪技术, 数字化输入封口位置, 避免粘刀和浪费包膜, 自动感应物料长度, 有产品时自动包装, 无产品时自动停机等待, 节省时间和膜料。
4. 传动系统采用同步带结构, 紧凑传递精度高, 维护保养方便。
5. 可调式承袋器采用全铜材质的滑板, 尺寸调节更精准。
6. 单悬臂结构设计, 并设有刀座定位槽, 更换刀座无需调节。
7. 机架采用焊接厚板一体成型, 运行更稳定。外观使用闪光鳞汽车钣金。
8. 高精度发卡机, 零误差发卡功能, 触摸屏简易设置, 单张或多张都可。
9. 螺丝自动计数, 自动包装, 自动下料, 缺料自动报警功能!
1. Three servo motors equipped with PLC control, independent temperature PID control, adapt to the needs of various packaging materials.
2. Simple man-machine interface, convenient parameter setting, with fault self-diagnosis function. All control is realized by software, easy to adjust and technology upgrade.
3. Adopting advanced photoelectric eye color-coded tracking technology, digitally inputting sealing and cutting position, avoiding sticking knife and wasting wrapping film, automatically sensing the length of the material, automatically packing when there are products and stopping and waiting when there are no products, saving time and film material.
4. The transmission system adopts synchronous belt structure, high precision of compact transmission and easy maintenance.
5. Adjustable bag carrier adopts full copper material slide plate, the size adjustment is more accurate.
6. Single cantilever structure design, and equipped with knife seat positioning slot, replacement of knife seat without adjustment.
7. The frame is made of welded thick plate, more stable operation. Appearance using flash scale automobile sheet metal.
8. High-precision card issuance machine, zero error card issuance function, touch screen easy to set up, single or multi-sheet can be.
9. Screw automatic counting, automatic packaging, automatic discharging, lack of material automatic alarm function!

选配装置 Optional Devices

- | | |
|------------|---------------|
| 1. 打码机 | 2. 打孔机 |
| 3. 全不锈钢 | 4. 触摸屏 |
| 5. 充气装置 | 6. 排气装置 |
| 7. 无物料停机功能 | 8. 自定义封口图案或封纹 |
| 9. 自动进料装置 | 10. 自动收料装置 |
1. Date coder
 2. Automatic punching Device
 3. Full Stainless
 4. Touch Screen
 5. Air filling device
 6. Release the exhaust device
 7. No empty bag function
 8. Customized sealing patterns and notch
 9. Automatic feeder
 10. Automatic collection device

技术参数 Technical parameters

Model 机型	SK-35XD
Film width 薄膜宽度	Max.350mm
Bag length 制袋长度	100-400mm
Bag width 制袋宽度	50-160mm
Product height 产品高度	Max.60mm
Film roll diameter 膜卷直径	Max.320mm
Packing speed 包装速度	10-60bags/min
Powder 电源规格	220V, 50/60Hz, 2.8KW
Dimension 机器尺寸	(L)4020x(W)720x(H)1320mm
Machine weight 机器重量	960kg



YB-Gloves packing machine



产品参数

电源电压:AC 220V
 设备功率:12KW
 制袋长度:80-500mm
 制袋宽度:40-120mm
 包装速度:20-60PCS/min
 设备总重:4000kg
 外形尺寸:6105x820x1404mm

Product Parameters

supply voltage: AC 220V
 equipment power: 12KW
 bag length:80-500mm
 bag width: 40-120mm
 packing speed: 20-60PCS/min
 machine weight: 4000kg
 machine dimension:6105x820x1404mm

性能和特点 Features

自动手套包装线是一套高自动化生产线,由一对手套包装机,自动送料堆叠机,自动中包机,机械手,自动纸箱成型机,自动封箱机组成,您可以添加选项,如自动发卡机,自动贴标机,自动开箱机,全自动纸盒封口机等。

主包装机采用皮带进料输送包装方式,由三台伺服电机控制完成自动包装,智能化程度高,操作简单等特点。
 自动感应物料长度,自动包装产品,有产品自动启动,无产品自动停机,不耗膜。

Automatic glove packing line is a set of highly automated production line, which consists of a pair of glove packing machine, automatic feeding and stacking machine, automatic center wrapping machine, robotic hand, automatic carton forming machine, automatic carton sealing machine, and you can add options, such as automatic card dispenser, automatic labeling machine, automatic carton opener, automatic carton sealing machine and so on.

The main packaging machine adopts belt feeding and conveying packaging method, controlled by three servo motors to complete automatic packaging, high degree of intelligence, simple operation and other features.

Automatic sensing material length, automatic packaging products, automatic start with products, no products automatic stop. No film consumption.

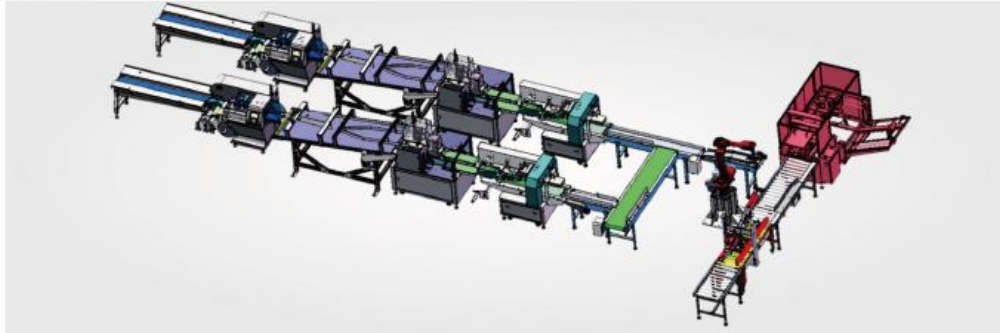

Automatic carton packing machine



产品介绍:

本套设备是集开盒、装料、折页、喷胶、封盒、理料点数、开箱、装箱为一体,适用于多品种,多规格的纸盒包装机,由PLC微电脑控制,自动报警,故障提示。采用人机界面操作系统,自动显示装盒速度、数量、故障原因等性能参数,采用自润滑系统运行更加平稳。机体采用优质不锈钢、烤漆与铝材结合。在同台设备中规定范围内可实现多规格的调整使用。手动和自动转换功能,可配热熔胶机,可按客户需求定制。

Product Introduction:

This set of equipment is a set of box opening, loading, folding, spraying, sealing, sorting points, opening, packing as a whole, suitable for multiple varieties, multi-specification carton packaging machine, controlled by PLC microcomputer, automatic alarms, fault prompts. Adopting man-machine interface operating system, it automatically displays the performance parameters such as cartoning speed, quantity, and cause of failure, and adopts self-lubricating system to run more smoothly. The machine body adopts high quality stainless steel, baking paint and aluminum combination. Adjustable use of multiple specifications can be realized within the prescribed range in the same machine. Manual and automatic conversion function, can be equipped with hot melt glue machine, can be customized according to customer needs.



Automatic cartoning line



Automatic small+middle cartoning line



Automatic group packing application

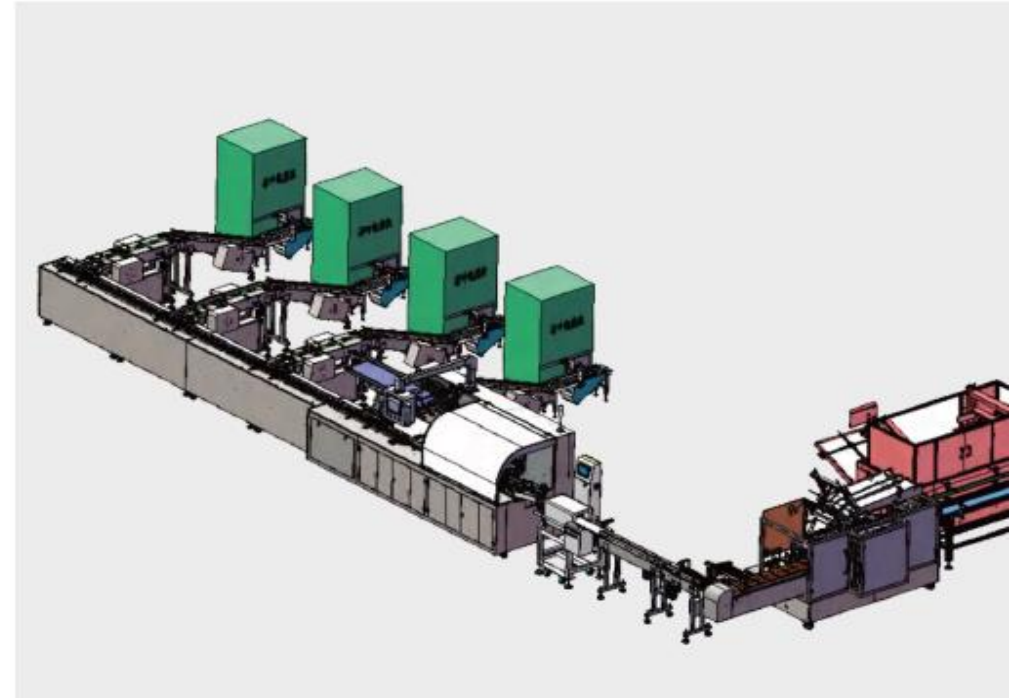
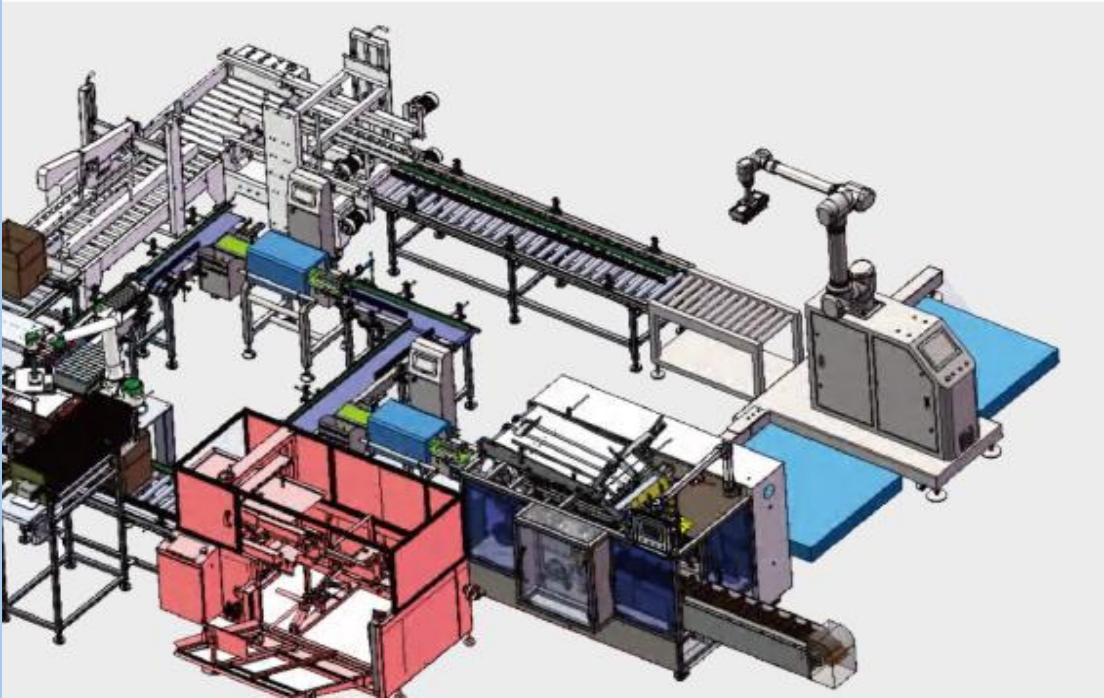

Automatic visual counting and packing



Two level lifting, weighting, packing, inspection



Automatic packing application

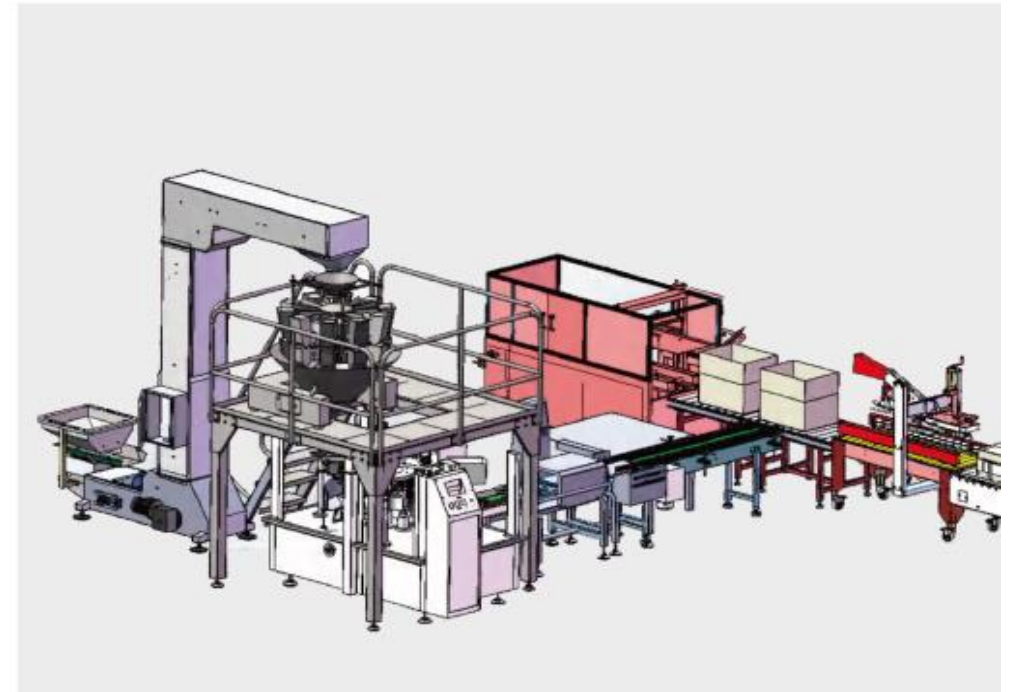
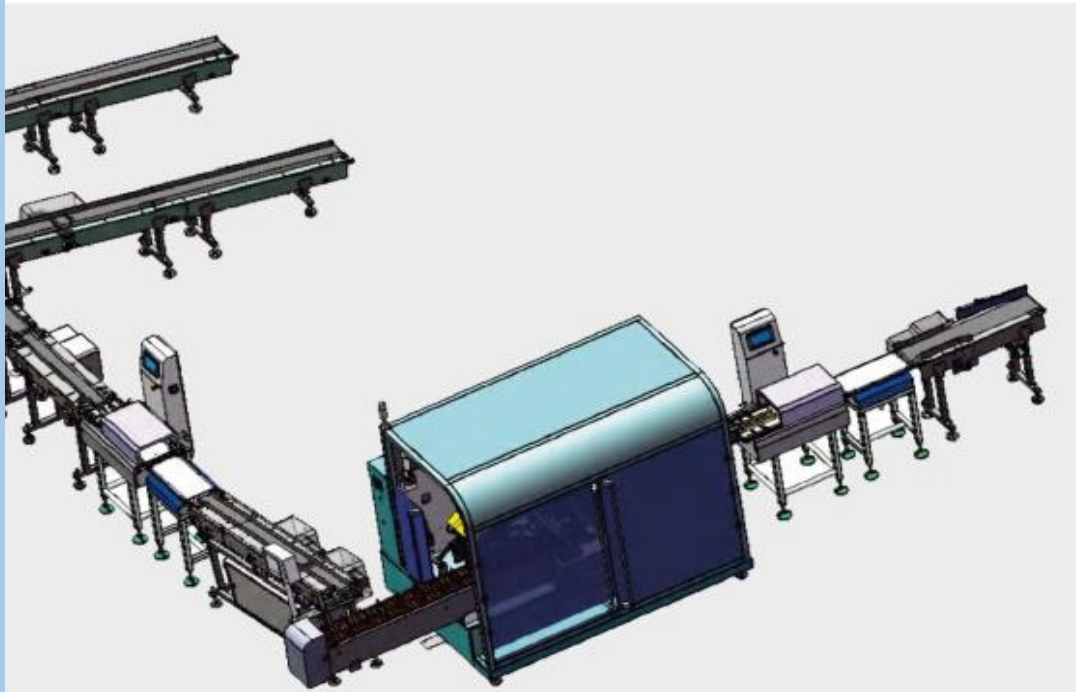

YBCW-150 high speed online check weigher

YB-220 Online check weigher

功能特点 Features

- ◎ 触摸屏人机对话
User-friendly operating system.
- ◎ 中英文操作界面
Chinese-English interface;
- ◎ 重量补偿功能
Weight of products can be compensated
- ◎ 柱状图和曲线图用来客户分析产品合格率
Product qualification ratio can be showed in line graphs and bar charts
- ◎ 三级操作权限管理, 支持自设密码
Three-level operation authority management, support self-set password
- ◎ 可 100 个产品配方预设存储
100 kinds of data can be stored with strong data statistics function.
- ◎ 不合格产品多种剔除方式。
Support multi-methods of rejection



选配 Optional

- ◎ U 盘接口
USB Port
- ◎ RS485/232/网口通信接口
RS485/232/LAN connection port
- ◎ 声光报警灯
Sound-light alarming lamp

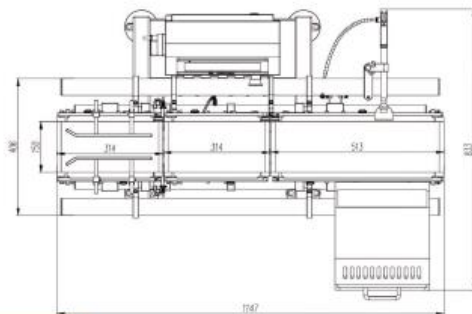

型号 Type	SKCW-150
称重范围 Weighing scope:	3-500g
产品限制 Restrictions of product:	L:200 W:150 H:3-200(mm)
分选精度 Accuracy:	±0.1g (视产品) (Depends on products)
分度值 Division Scale:	0.1g
皮带速度 Belt speed:	0-90m/min
最高速度 Highest speed:	250pcs/min
皮带宽度 Belt Width:	150mm
机器自重 Weight of Machine:	70Kg
电源 Power Supply:	AC 220V 50HZ
功率 Power:	≈100w
主要材质 Main Material:	SUS304 不锈钢 (Stainless Steel)

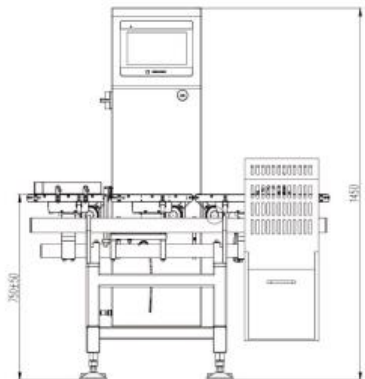

功能特点 Features

- ◎ 触摸屏人机对话
User-friendly operating system.
- ◎ 中英文操作界面
Chinese-English interface;
- ◎ 重量补偿功能
Weight of products can be compensated
- ◎ 柱状图和曲线图用来客户分析产品合格率
Product qualification ratio can be showed in line graphs and bar charts
- ◎ 三级操作权限管理, 支持自设密码
Three-level operation authority management, support self-set password
- ◎ 可 100 个产品配方预设存储
100 kinds data can store with strong data statistics function.
- ◎ 不合格产品多种剔除方式。
Support multi-methods of rejection



选配 Optional

- ◎ U 盘接口
USB Port
- ◎ RS485/232/网口通信接口
RS485/232 /LAN connection port
- ◎ 声光报警灯
Sound-light alarming lamp

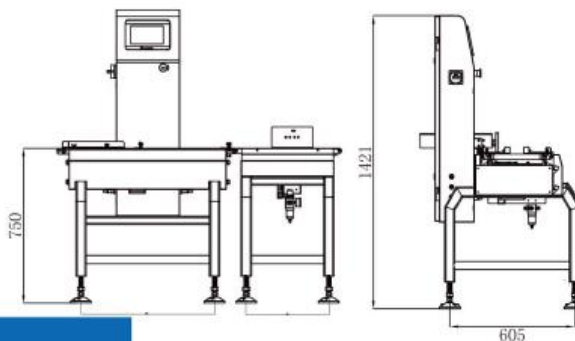

型号 Type	SK-220
称重范围 Weighing scope:	5-1500g
产品限制 Restrictions of product:	L:300 W:220 H:3-200(mm)
分选精度 Accuracy:	±0.2g 视产品 (Depends on products)
分度值 Division scale:	0.1g
皮带速度 Belt speed:	0-60m/min
最高速度 Highest speed:	100pcs/min
皮带宽度 Belt width:	220mm
机器自重 Weight of machine:	≈85Kg
电源 Power supply:	50HZ
功率 Power:	≈200W
主要材质 Main material:	SUS304 不锈钢 (Stainless Steel)

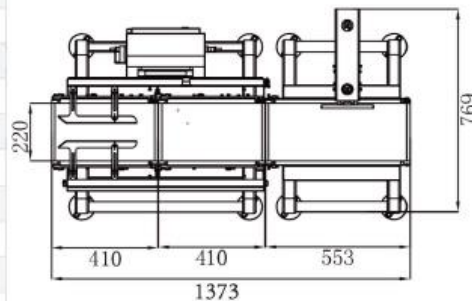

On-line weight verification

YB-Left/right sorting scale

功能特点Features

- ◎ 触摸屏人机对话
Touch screen man-machine dialogue operation
- ◎ 默认中英文操作界面（可定制多国语言）
Default Chinese and English operation interface (can be customized in multiple languages)
- ◎ 三级管理权限，支持自设密码
Three-level management authority, support self-set password
- ◎ 可存储100组配方
Can store 100 sets of recipes
- ◎ 剔除方式左右输送
Rejection mode left and right conveying
- ◎ 带有空包光电自动检测
With photoelectric automatic detection of empty packages



选配Optional

- ◎ U盘接口
USB Port
- ◎ RS485/232/网口通讯接口
RS485/232/LAN connection port
- ◎ 声光报警灯
Sound-light alarming lamp

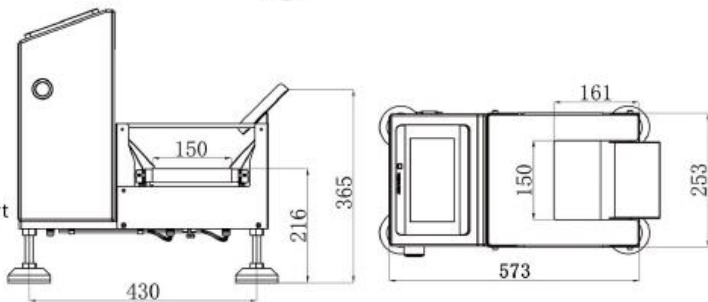

型号 Type	SUK 左右分选检重秤
称重范围 Weighing scope:	0-300g
分选精度 Accuracy:	±0.1视产品 (Depends on products)
最高速度 Highest Speed:	40pcs/min
皮带宽度Belt width:	150mm
产品限制Restrictions of product	L:200 W:150 H:3-50mm
剔除方式Reject type	左右输送（合格朝右，不合格朝左） Left and right transport (pass direction right, fail direction left)
电源Power Supply	AC 220V 50HZ
功率 Power	≈200w
机器自重Weight of Machine	≈15kg
整机材质 Main Material	SUS304不锈钢 (Stainless Steel)

YB-450 online check weigher

功能特点Features

- ◎ 触摸屏人机对话
User-friendly operating system.
- ◎ 中英文操作界面
Chinese-English interface;
- ◎ 重量补偿功能
Weight of products can be compensated
- ◎ 柱状图和曲线图用来客户分析产品合格率
Product qualification ratio can be showed in line graphs and bar charts
- ◎ 三级操作权限管理，支持自设密码
Three-level operation authority management, support self-set password
- ◎ 可100个产品配方预设存储
100 kinds of data can be stored with strong data statistics function
- ◎ 不合格产品多种剔除方式。
Support multi-methods of rejection



选配Optional

- ◎ U盘接口
USB Port
- ◎ RS485/232/网口通信接口
RS485/232/LAN connection port
- ◎ 声光报警灯
Sound-light alarming lamp

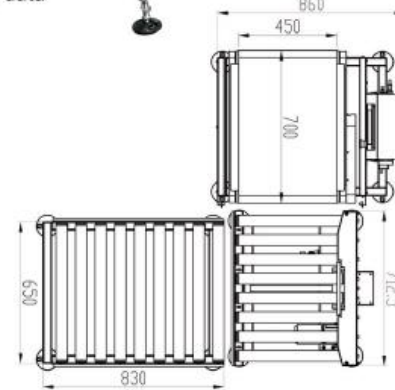

型号 Type	SUK-450
称重范围 Weighing scope:	0.05-30Kg
产品限制 Restrictions of product:	L:550 W:450 H:3-400mm
分选精度 Accuracy:	±5/10g (视产品) (Depends on products)
分度值 Division Scale:	1g
皮带速度 Belt speed:	0-60m/min
最高速度 Highest speed:	40pcs/min
皮带宽度 Belt Width:	450mm
机器自重 Weight of Machine:	≈40Kg+70Kg+45Kg
电源 Power Supply:	AC 220V 50HZ
功率 Power:	≈400w
主要材质 Main Material:	SUS304 不锈钢 (Stainless Steel)

Metal detector & check weigher



型号 Type	数字式金属检测称重机 Digital Checkweigher with Metal Detector Combo (尺寸规格可根据要求定制 Accept custom)		
型号 Type	SUK	规格: Specifications	4010
检测孔宽度 Detection of hole width:	150mm	检测孔高度: Inspection hole height	100-200mm
检测灵敏度 Detection sensitivity:	空机状态下 In the empty state: 高 (H) 100mm 铁 Fe \geq ϕ 0.8mm, 不锈钢 SUS \geq ϕ 1.2mm 高 (H) 120mm 铁 Fe \geq ϕ 1.0mm, 不锈钢 sus \geq ϕ 1.8mm 高 (H) 150mm 铁 Fe \geq ϕ 1.2mm, 不锈钢 sus \geq ϕ 2.0mm 高 (H) 200mm 铁 Fe \geq ϕ 1.5mm, 不锈钢 sus \geq ϕ 2.5mm		
有效检测孔宽度 Effective hole width detection:	150mm		
有效检测孔高度 Effective hole detection level:	100-200m		
称重量程范围 Weighing scale range:	5-500g		
称重精度 Weighing accuracy:	\pm 0.1g 视产品 (Depends on products)		
传送带高度 Conveyor height:	750mm (\pm 50mm)		
输送能力 Transmission capacity:	10kg/times次	传送方向 Transfer direction:	由左向右 From left to right
传送带最大速度 Conveyor belt maximum speed:	25m/min	传送带材质 Material for conveyor belt:	食品级 PU 带 Food grade PU belt
防护等级 Protection grade:	IP65		

Digital all metal detector

产品描述 The product description

全自动数字式金属检测机系统可以识别各种磁性以及非磁性金属 (如铁、不锈钢、铝等), 即便是细微金属内嵌于产品中也可以被检测识别到。

Automatic digital all-metal detector machine system can identify the various magnetic and nonmagnetic metal (such as iron, stainless steel, aluminum, etc.), even a tiny metal embedded in the product can also be tested to recognize.



型号 Type	数字式全金属检测机 Digital All-metal Detector Machine (尺寸规格可根据要求定制 Accept custom)		
检测灵敏度 Detection sensitivity	空机状态下 Empty state 高 (H) 100mm: 铁 Fe \geq ϕ 0.8mm, 非铁 Non-Fe \geq ϕ 1.5mm, 不锈钢 SUS \geq ϕ 1.5mm 高 (H) 120mm 铁 Fe \geq ϕ 0.8mm, 非铁 Non-Fe \geq ϕ 1.5mm, 不锈钢 sus \geq ϕ 2.0mm 高 (H) 150mm 铁 Fe \geq ϕ 1.0mm, 非铁 Non-Fe \geq ϕ 1.5mm, 不锈钢 sus \geq ϕ 2.0mm 高 (H) 200mm 铁 Fe \geq ϕ 1.2mm, 非铁 Non-Fe \geq ϕ 2.0mm, 不锈钢 sus \geq ϕ 2.5mm		
有效检测孔宽度 Effective hole width detection:	150-1000mm 根据要求定制 (Accept custom)		
有效检测孔高度 Effective hole detection level:	80-500mm 根据要求定制 (Accept custom)		
传送带最大速度 Conveyor belt, maximum speed:	25m/min	传送带材质: Material for conveyor belt	食品级 PU 带 Food grade PU belt
防护等级 Protection grade:	IP65		
显示及操作方式 Display and operation mode:	LED 液晶平面按键输入 LED flat key input		
机器自重 Deadweight of Machine:	\approx 120Kg		
电源要求 Power supply requirements:	AC 220V 50Hz		
功率 Power:	\approx 200w		
报警方式 Alarm way:	检测到金属, 声光警报和自动剔除 Metal detected, audible and visual alarms and automatic rejection		
外形尺寸 Overall dimensions:	About L1500XW850XH950mm 最终按照设计图为准 (Design drawing prevail)		