

AUTOMATIC CARTON PACKING AND TRANSFER SOLUTION

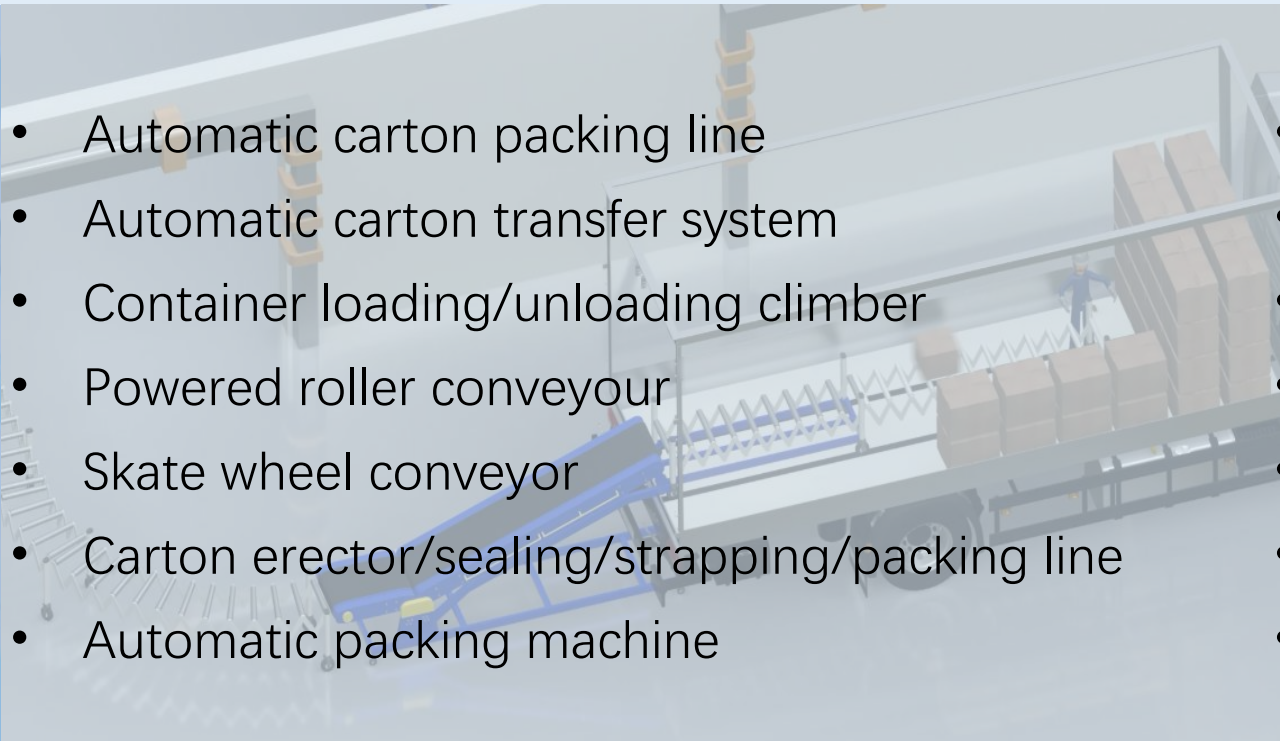

- Automatic carton packing line
- Automatic carton transfer system
- Container loading/unloading climber
- Powered roller conveyour
- Skate wheel conveyor
- Carton erector/sealing/strapping/packing line
- Automatic packing machine

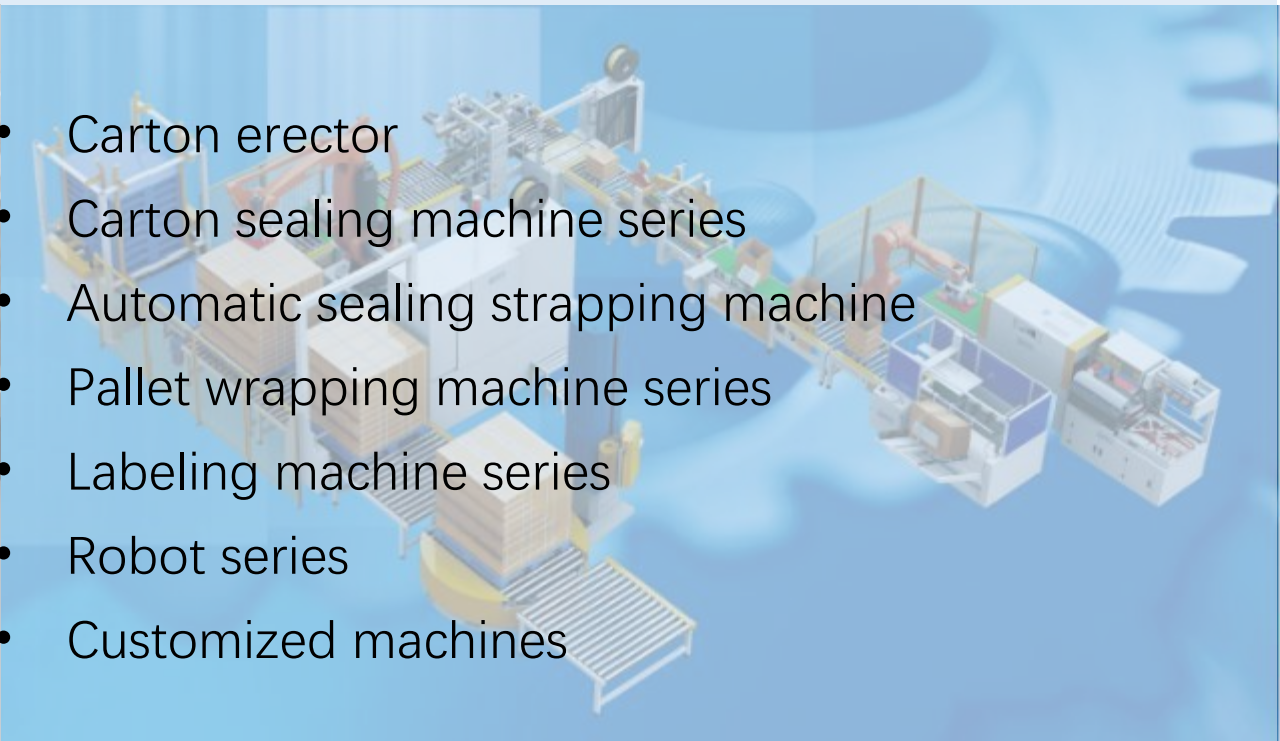

- Carton erector
- Carton sealing machine series
- Automatic sealing strapping machine
- Pallet wrapping machine series
- Labeling machine series
- Robot series
- Customized machines

Automatic carton packing line

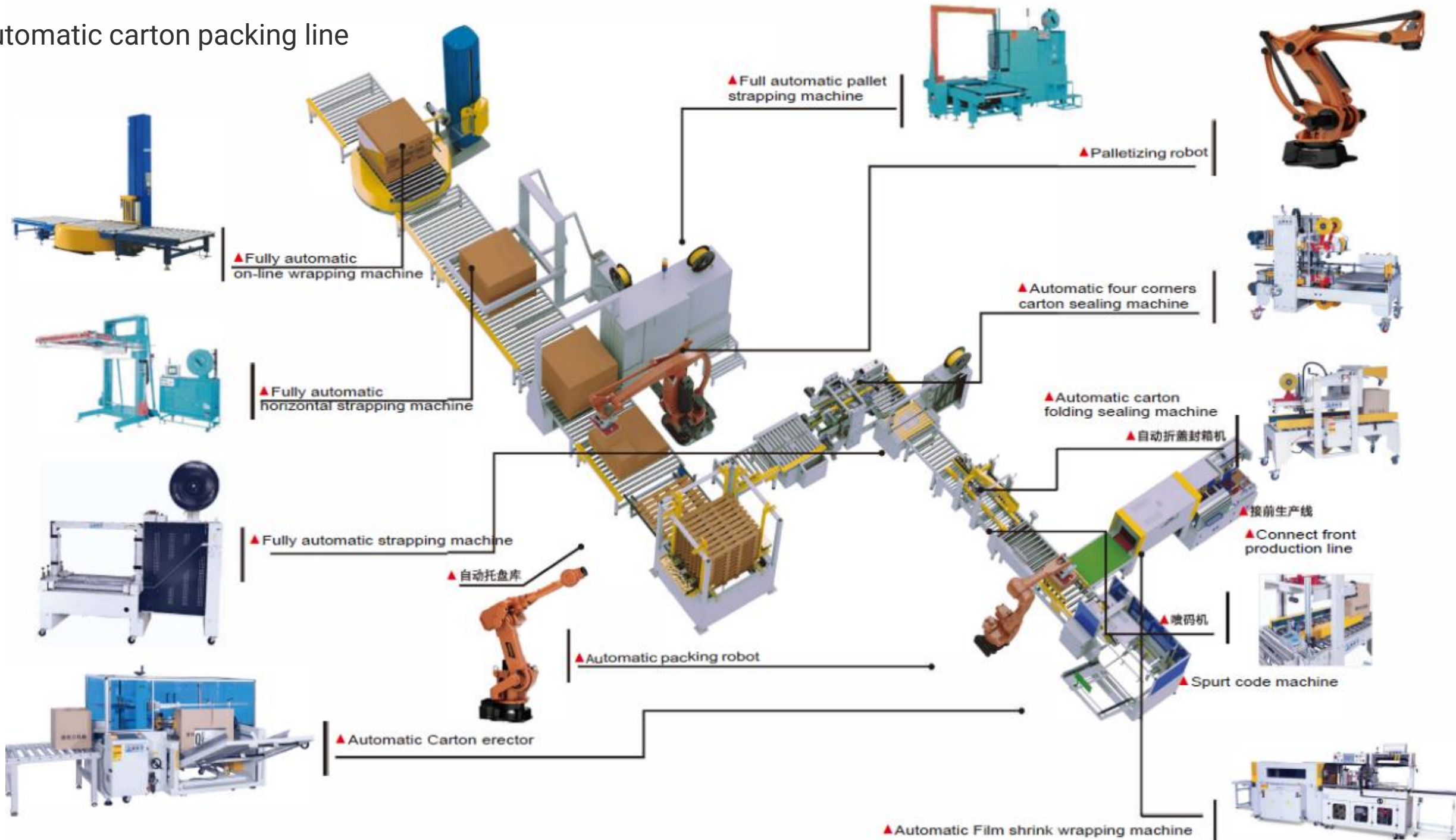

Carton transfer system. Flexible carton transfer inside of production line, warehouse and container loading and unloading, 2 direction moving options

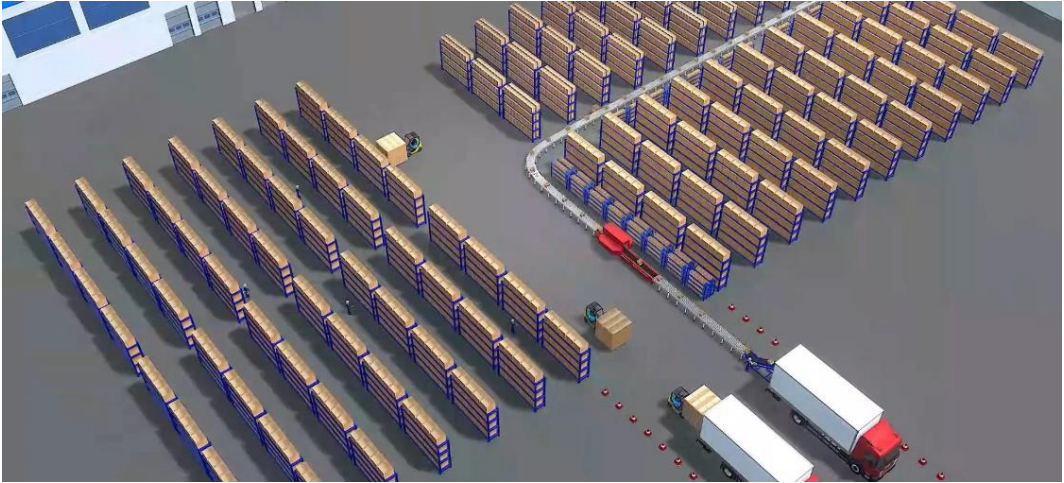

More Reliable



Hydraulic Conveyor

Watch packages travel smoothly from ground level directly into truck beds or...

More Flexible



Gravity Skate Wheel Conveyor

Gravity skate wheel conveyors harness natural physics for moving goods...

More Cost-effective



Gravity Roller Conveyor

Picture products gliding effortlessly across warehouse floors without...

▲ Carton erector, sealing and strapping packaging line

The automatic packaging assembly line including carton unpacking, sealing and strapping package. Wide application, small floor area, stable performance, simple operation, greatly reduce labor, improve production efficiency, reduce production cost. For the domestic dozens of large well-known enterprises to choose. Customized according to the customer's different packaging design.



▲ Automatic four corners carton sealing machine



▲ Automatic carton erector

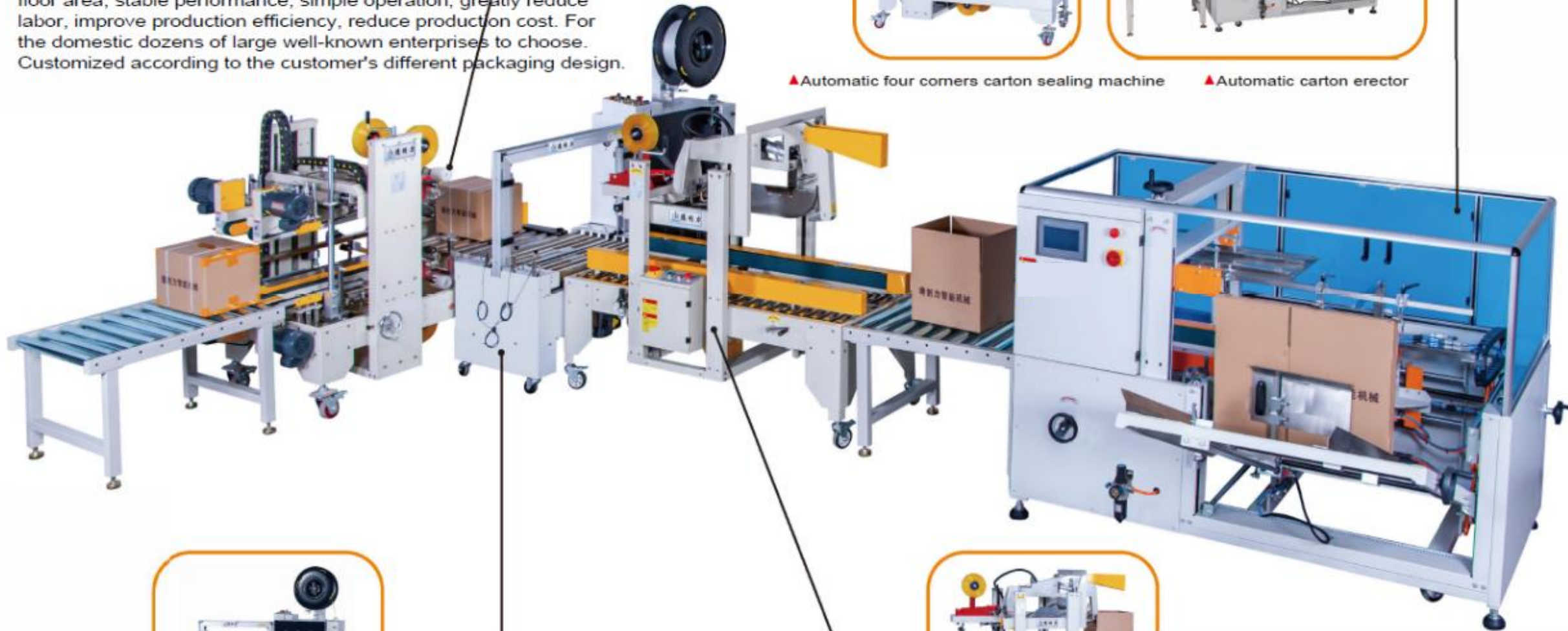

▲ Automatic strapping machine



▲ Automatic double column folding sealing machine

▲ Grab packing machine

Product features:

The product is suitable for the centralized packing of all kinds of auxiliary materials after arrangement, the highest speed is about 15 times/min, which ensures the fast operation and reduces the manufacturing cost of high-speed boxing manipulator parts and the processing requirements of supporting equipment, and the cost is low.

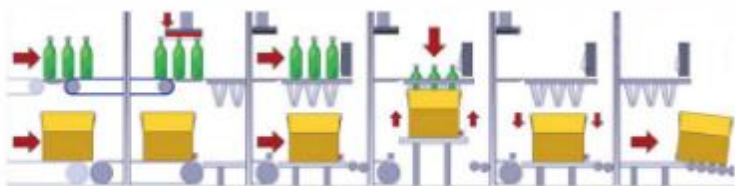
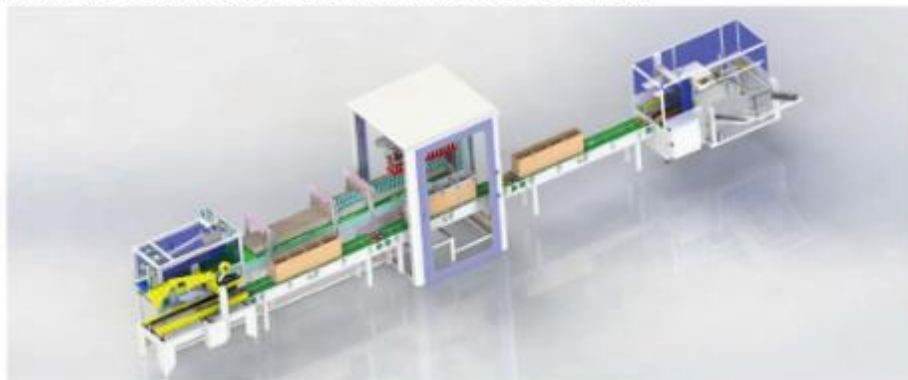

▲ Side push packing machine

Product features:

The side push boxing machine is suitable for block material side push boxing with regular shape. It can complete the function of arrangement, stacking and packing of block material automatically. It can meet the requirements of quantity of material per box and different packing methods, and can realize fast switching.

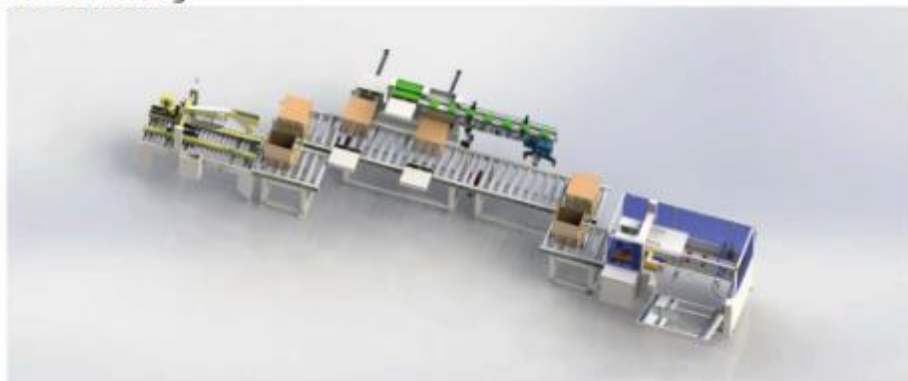

Scheme one : Automatic folding H-shape sealing packing line



Scheme two: Automatic folding H-shape sealing packing line

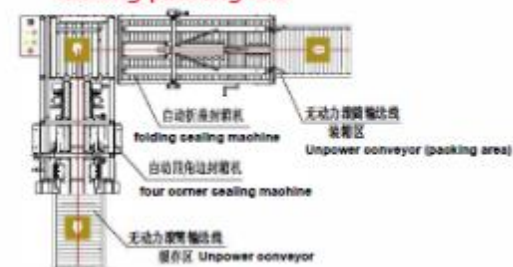

Scheme three: Automatic carton erector, straight type 王-shape carton packing line

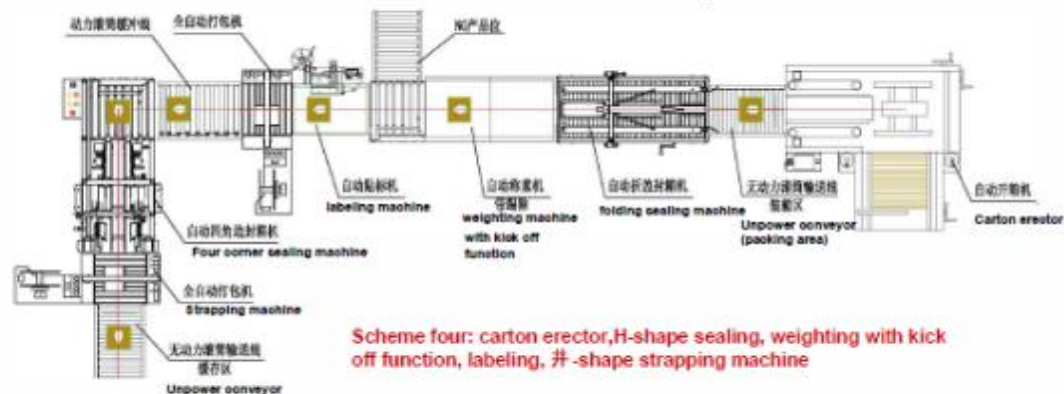
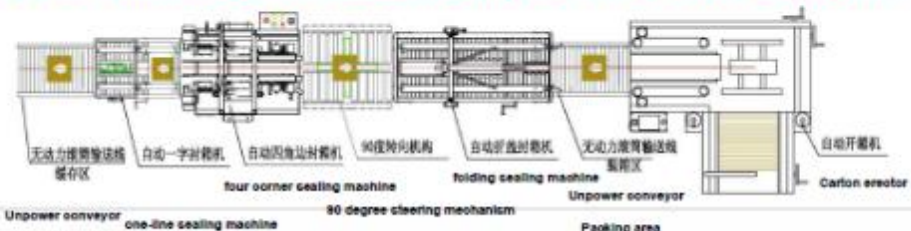

Scheme four: carton erector, H-shape sealing, weighting with kick off function, labeling, 井-shape strapping machine

Scheme Five: Automatic shrink wrapping, carton erector, product packing, sealing, strapping, palletted packing line





Product features:

- Adopt the international advanced technology, and choose imported parts, electrical components and pneumatic Components.
- Vertical storage of cardboard, and can be supplied carton board at any time, no need to stop.
- Applicable to the same carton size packaging at the same time, if the carton size needs to be changed, manual adjust the width and high of machine, need 1-2 minutes.
- Reasonable design, absorb and open carton, fold the lower cover and sealing.
- Light weight, precise and durable performance, no vibration in the process of operation, long life and high efficiency.
- Add transparent glass protective cover to avoid operation accident.
- Single machine operation, also can be used with automatic packaging assembly line.



Carton Unpacking Bottom Sealing Finish

▲ DPK-40 Carton erector

主要技术参数

Model	DPK-40	DPK-50	DPK-40H18
Unpacking speed	12 cartons/min	10 cartons/min	18 cartons/min
Carton stock	1 00pcs (1 000mm)	100pcs (1000mm)	100pcs (1000mm)
Carton size	L: 250-450 W: 150-400 H: 100-400mm	L:250-700 W: 150-500 H: 150-500mm	L: 200-400 W: 150-350 H: 100-350mm
Power	220V 1φ 200W	220V 1φ 200W	220V 1φ 200W
Air compressing	6kg/cm ²	6kg/cm ²	6kg/cm ²
Air consumption	450NL/min	450NL/min	450NL/min
Machine Dimension	L2000 x W1900 x H1450mm	L2300 x W2100 x H1530mm	L2400 x W2050 x H 1450mm
Net weight	490kg	560kg	550kg
Tape Width	W48, 60, 72mm	W48, 60, 72mm	W48, 60, 72mm



Product features:

- Absorb Japan, Germany advanced technology, and select imported parts, electricity Device components and pneumatic components.
- The whole machine adopts CAM continuous system, precise, stable and durable.
- The unpacking and sealing box are controlled by frequency converter, the speed can be adjusted and save time.
- Simple operation, easy adjustment, no doubt of damage to the carton.
- Carton storage is horizontal, can be replenished empty carton at any time, no need to stop.
- Automatic warning reminder supplement carton.
- Add transparent glass protective cover, open the door and stop automatically to avoid operation accident.
- Single machine operation, also can be used with automatic packaging assembly line.



Prepare Unpacking Carton Unpacking Bottom folding Bottom sealing

▲ DPK-4030 Horizontal Carton erector

主要技术参数

Model	DPK-40H30	DPK-40H50
Unpacking speed	30 cartons/min	50 cartons/min
Carton stock	80PCS (800MM)	80PCS (800MM)
Carton size	L: 240-510 W: 190-400 H: 120-400mm	L: 250-450 W: 150-400 H: 100-300mm
Power	380V 3φ 746W	380V 3φ 746W
Air compressing	5kg/cm ²	6kg/cm ²
Air consumption	300NL/min	400NL/min
Machine Dimension	L2372 x W1210 x H1820mm	L3120 x W1250 x H1740mm
Net weight	1000kg	1200kg
Tape Width	W48, 60mm	W48, 60mm

▲DPA-50 Left + right belt drive sealing machine

Product Feature:

- Adopt international advanced technology, and select imported parts, electrical components.
- According to carton specification, manually adjust width and height.
- Two side belt drive, up and bottom sealed box, economical, fast and smooth.
- Equipped with blade protection device to avoid accidental injury during operation.
- Single machine operation, also can be used with automatic packaging assembly line.

主要技术参数

Model	DPA-50
Conveying speed	0-20m/min
Max carton size	L∞ x W500 x H500mm
Min carton size	L150 x W150 x H120mm
Power	220V 50Hz
Consumption	180W
Tape width	W48mm, 60mm, 72mm
Machine Dimension	L1020 x W850 x H1350 (exclude front and rear roller frame)
Machine weight	120kg



Manually folding Manually push in up and down sealing Finish

▲DPA-50P Left + right + up belt drive sealing machine

Product Feature:

- Adopt international advanced technology, and select imported parts, electrical components.
- According to carton specification, manually adjust width and height.
- With both sides and up belt drive, suitable for sealing box of larger and heavier carton, economical, fast and stable.
- Equipped with blade protection device to avoid accidental injury during operation.
- Single machine operation, also can be used with automatic packaging assembly line.

主要技术参数

Model	DPA-50P
Conveying speed	0-20m/min
Max carton size	L∞ x W500 x H500mm
Min carton size	L150 x W180 x H150mm
Power	220V 50Hz
Consumption	270W
Tape width	W48mm, 60mm, 72mm
Machine Dimension	L1020 x W900 x H1350 (exclude front and rear roller frame)
Machine weight	130kg



Manually folding Manually push in up and down sealing Finish

▲DPA-4030 E-commerce carton sealing machine

Product Feature:

- Adopt international advanced technology, and select imported parts, electrical components.
- According to carton specification, manually adjust width and height.
- Left and right belt drive, inlet drum encryption, suitable for e-commerce 1-12 carton sealing.
- Equipped with blade protection device to avoid accidental injury during operation.
- Single machine operation, also can be used with automatic packaging assembly line.

主要技术参数

Model	DPA-4030
Conveying speed	0-20m/min
Max carton size	L∞ x W300 x H400mm
Min carton size	L130 x W80 x H90mm
Power	220V 50Hz
Consumption	180W
Tape width	35-50mm
Machine Dimension	L 1020 x W650 x H1250 (exclude front and rear roller frame)
Machine weight	110kg



Manually folding Manually push in up and down sealing Finish

▲DPB-56 Up + down belt drive sealing machine

Product Feature:

- Adopt international advanced technology, and select imported parts, electrical components.
- According to carton specification, manually adjust width and height.
- With up and down belt drive, up and down sealing at the same time, economical, fast and smooth.
- Equipped with blade protection device to avoid accidental injury during operation.
- Single machine operation, also can be used with automatic packaging assembly line.

主要技术参数

Model	DPB-56
Conveying speed	0-20m/min
Max carton size	L∞ x W500 x H600mm
Min carton size	L150 x W180 x H150mm
Power	220V 50Hz
Consumption	180W
Tape width	W48mm, 60mm, 72mm
Machine Dimension	L1020 x W850 x H1450 (exclude front and rear roller frame)
Machine weight	120kg



Manually folding Manually push in up and down sealing Finish

▲DPS-50 both sides sealing machine

Product Feature :

- Adopt international advanced technology, and select imported parts, electrical components.
- According to carton specification, manually adjust width and height.
- Suitable for carton with side opening, such as beverage, floor tile, etc.
 - Up and down belts drive, sealing carton on both sides, economical, fast and stable.
- Equipped with blade protection device to avoid accidental injury during operation.
- Single machine operation, also can be used with automatic packaging assembly line.

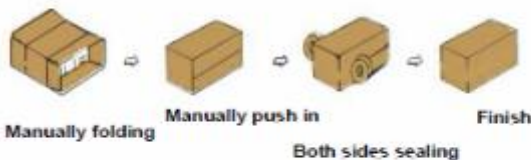

Manually folding Manually push in Both sides sealing Finish

主要技术参数

Model	DPS-50
Conveying speed	0-20m/min
Max carton size	L∞ x W500 x H450mm
Min carton size	L150xW250xH90mm (zinchi /120mm (zinchi)
Power	220V 50Hz
Consumption	240W
Tape width	W48mm, 60mm, 72mm
Machine Dimension	L860 x W930 x H1250 (exclude front and rear roller frame)
Machine weight	150kg

▲DPD-46 side belt drive sealing machine

Product Feature :

- Adopt international advanced technology, and select imported parts, electrical components.
- According to carton specification, manually adjust width and height.
- Suitable for high - side carton sealing, such as computer and television boxes.
- Up and down side belts drive, carton up and down sealing, economical, fast and stable.
- Equipped with blade protection device to avoid accidental injury during operation.
- Single machine operation, also can be used with automatic packaging assembly line.



Manually folding Manually push in Up and down sealing Finish

主要技术参数

Model	DPD-46
Conveying speed	0-20m/min
Max carton size	L∞ x W400 x H600mm
Min carton size	L150 x W150 x H240mm
Power	220V 50Hz
Consumption	480W
Tape width	W48mm, 60mm, 72mm
Machine Dimension	L1020 x W880 x H1500 (exclude front and rear roller frame)

▲DPE-50 Full automatic sealing machine

Product Feature :

- Adopt international advanced technology, and select imported parts, electrical components.
- According to carton specification, Automatically adjust width and height.
- Two side belts drive, up and bottom sealing box, economical, fast and smooth.
- Can be customized on both sides and up belt drive, can bear up to 50kg.
- Equipped with blade protection device to avoid accidental injury during operation.
- Single machine operation, also can be used with automatic packaging assembly line.



Manually folding Manually push in Up and down sealing Finish

主要技术参数

Model	DPE-50 / DPE-50P
Conveying speed	0-20m/min
Max carton size	L∞ x W500 x H500mm
Min carton size	L150 x W150 x H140mm
Power	220V 50Hz 6kg/cm3
Consumption	240W
Tape width	W48mm, 60mm, 72mm
Machine Dimension	L 1170 x W900 x H1350 (exclude front and rear roller frame)
Machine weight	170kg

▲DPJ-01Automatic code spraying machine

Product Feature:

- USB transfer print information, simple and fast.
- Compact design, does not take up space, can be quickly installed.
- Matching HP original high quality ink box, fast drying, no blocking.
- Attached with the computer terminal editing software and U disk.



主要技术参数

Model	DPJ-01
Printing height	9 mm
Power	220V, 50/60HZ
Printing length	512 characters
Printing direction	Spray horizontally and downward
Printing distance	5mm(Spray nozzle to print surface)
Printing lines	1-4 lines
Print resolution	300dpi
Data transmission interface	USB (Low Ink alarm)
Internal memory	30 Group spurt data
Weight	0.85kg (excluding mounting bracket)



▲ DPC-50 Automatic double column folding and sealing machine

Product Feature:

- Adopt international advanced technology, and select imported parts, electrical components.
- According to carton specification, manually adjust width and height.
- Automatic folding upper cover, upper and bottom carton sealing, fast, smooth and beautiful.
- Equipped with blade protection device to avoid accidental injury during operation.
- Single machine operation, also can be used with automatic packaging assembly line.



Manually push in

Up and down sealing

Finish

主要技术参数	
Model	DPC-50
Conveying speed	0-20m/min
Max carton size	L600 × W500 × H500mm
Min carton size	L200 × W150 × H150mm (Non-Coexisting)
Power	220V 1 φ -3 f 50Hz-60Hz
Air compressing	6kg/cm ²
Consumption	400W
Tape width	W48mm, 60mm, 72mm
Machine Dimension	L1770 × W930 × H1520mm
Machine weight	230kg

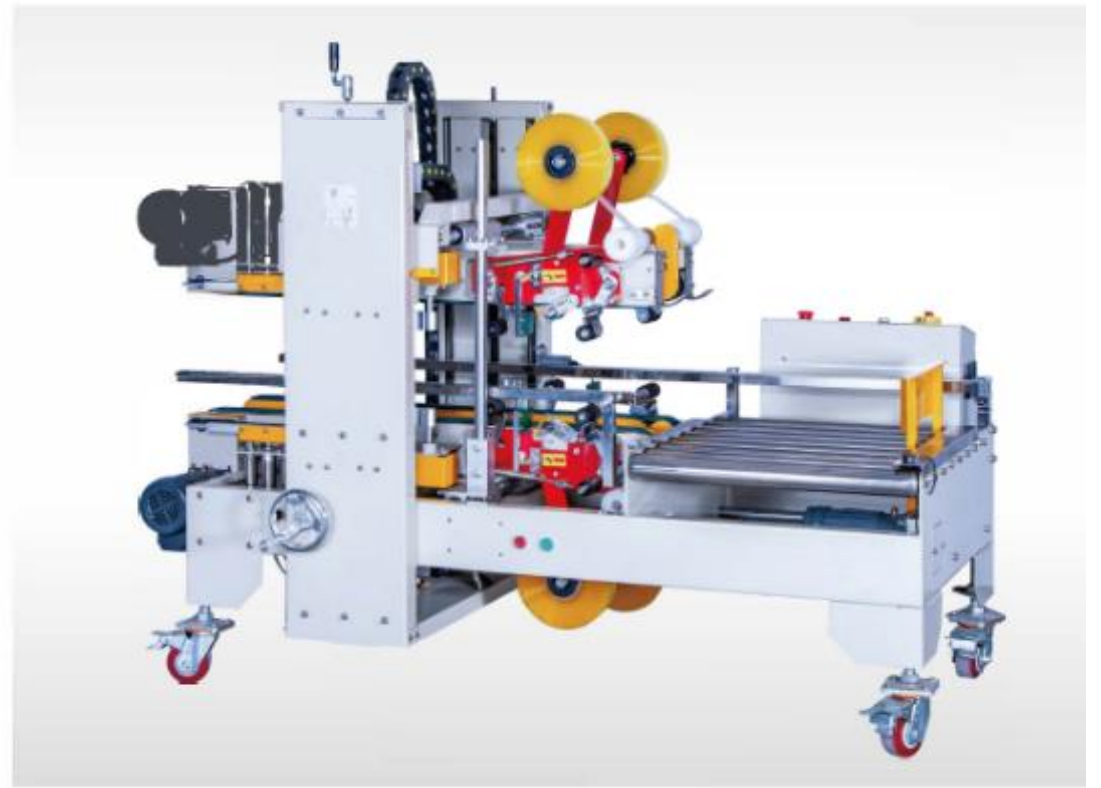

▲ DPG-755 Automatic four-corner sealing machine

Product Feature:

- The machine adopts PLC control, economical and durable, safe, low failure rate.
- Manually adjust the width and height of the machine according to carton specifications, suitable for the same specification carton sealing at the same time.
- After sealing the up and bottom tape, the L-shaped corner push, the carton move to perform the four-corner sealing and smoother operation.
- Seal carton is beautiful, fast, save manpower, high efficiency.
- Equipped with blade protection device to avoid accidental injury during operation.
- This machine can be combined with DPA DPB DPC on line to finish L-shape sealing.

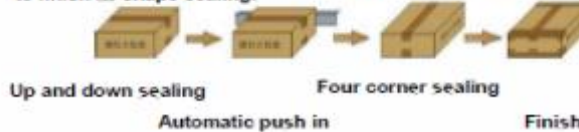

Up and down sealing

Four corner sealing

Automatic push in

Finish

主要技术参数	
Model	DPG-755
Carton size	L320-700 × W200-500 × H180-500mm
Platform height	600mm (can be customized)
sealing speed	480-800 cartons/hour
Machine dimension	L1900 × W1130 × H1530mm
Power	220V 1 φ -3 f 50-60Hz
Air compressor	6kg/cm ²
Tape width	W48mm, 60mm × L1000yard
Machine Weight	400kg



▲ DPA-50+DPG-755 Automatic H-shaped sealing machine

Product Feature:

- The automatic one-line sealing machine compatible with four-corner sealing machine, and then finish H-type sealing.
- Manually adjust the width and height of machine according to carton specifications, suitable for the same specification carton sealing at the same time.
- Carton sealing effect is beautiful, fast, save manpower, high efficiency.
- Simple operation, economical and durable, safe, minimum failure rate.

主要技术参数	
Model	DPA-50+DPG-755
Carton size	L320-700 x W200-500 x H180-500mm
Platform height	600mm (can be customized)
sealing speed	480-600 cartons/hour
Machine Dimension	L2620 x W2100 x H1580
Power	220V 1φ-3φ 50-60Hz
Air compressor	6kg/cm ²
Tape width	W48mm, 60mm x L1000yard
Machine Weight	550kg

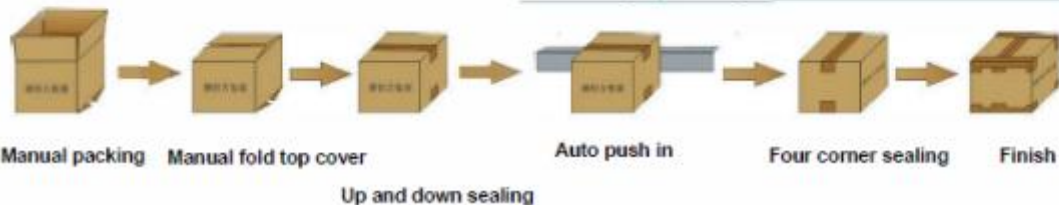

▲ DPC-50+DPG-755 Automatic folding and H-shaped sealing machine

Product Feature:

- The automatic folding one-line sealing machine compatible with four-corner sealing machine, and then finish H-type sealing.
- Manually adjust the width and height of machine according to carton specifications, suitable for the same specification carton sealing at the same time.
- Carton sealing effect is beautiful, fast, save manpower, high efficiency.
- PLC control operation is simple, economical and durable, safe, with the lowest failure rate.
- The width and height can be adjusted by one-button electric motor, which is more convenient for operation.

主要技术参数	
Model	DPC-50+DPG-755
Carton size	L320-700 x W200-500 x H180-500mm
Platform height	600mm (can be customized)
sealing speed	480-600 cartons/hour
Machine Dimension	L2970 x W2100 x H1580
Power	220V 1φ-3φ 50-60Hz
Air compressor	6kg/cm ²
Tape width	W48mm, 60mm x L1000 yard
Machine Weight	680kg

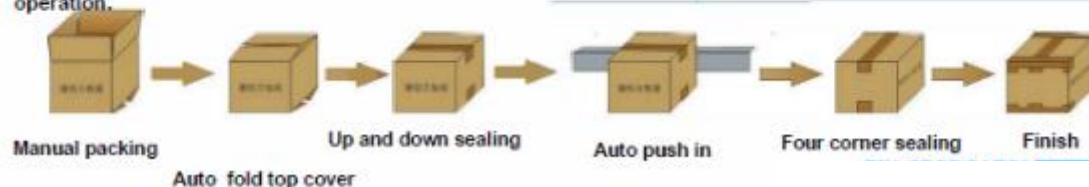



▲ DPI-50 Full automatic folding sealing machine

Product Feature:

- Adopt international advanced technology, and select imported parts, electrical components.
- Automatically adjust width and height according to carton specification, suitable for packing different sizes of carton at the same time.
- Automatic folding up cover, up and bottom carton sealing, fast, smooth and beautiful.
- PLC control operation is simple and convenient with strong applicability
- Equipped with blade protection device to avoid accidental injury during operation.
- Single machine operation, also can be used with automatic packaging assembly line.

主要技术参数	
Model	DPI-50
Conveying speed	0-20m/min
Max carton size	L500mm×W500mm×H500mm
Min carton size	L200mm×W150mm×H150mm
Power	220V 1φ-3φ 50-60Hz
Air compressing Consumption	6kg/cm ³ 400W
Tape width	W48mm、60mm
Machine Dimension	L1700mm×W880mm×H1450mm
Machine Weight	280kg



Manually push in Auto folding Up and down sealing Finish



▲ DPI-50+DPH-50 Full automatic folding and H-shaped sealing machine

Product Feature:

- The full automatic folding and one-line sealing machine compatible with four-corner sealing machine, and then finish H-type sealing. 一时段不同
- Automatically adjust the width and height of machine according to carton specifications, suitable for the different specifications carton sealing at the same time.
- Seal carton is beautiful, fast, save manpower, high efficiency.
- Simple operation, economical and durable, safe, minimum failure rate.

主要技术参数	
Model	DPI-50+DPH-50
Carton size	L320-500×W200-500×H180-500mm
Table height	600mm(Can be customized)
Conveying speed	300-360cartons/hours
Machine Dimension	L3000×W2100×H1580mm
Power	220V、1φ-3φ、50-60Hz
Air compressing Consumption	8kg/cm ³ 150NL/min
Tape width	W48mm/60mm L1000yard
Machine Weight	730kg

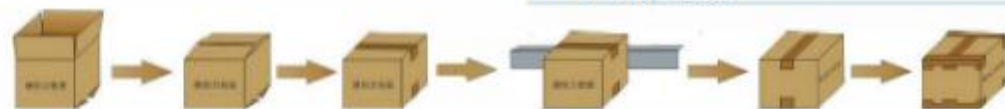

Manual packing Auto folding Up and down sealing Auto push in Four corner sealing Finish



▲DPP-50A Automatic sealing and strapping machine

Product introduction:

Automatic box sealing and baling machine is a kind of packing machine integrating automatic box sealing and baling, which can be used with automatic assembly line, automatic upper and lower sealing tape, multi-way baling, and unmanned packaging after realization. High work efficiency, widely used in toys, home appliances, printing brush, medicine, electronics, daily use crystal and other mass production industries.

Product Feature:

- Sealing and baling at the same time, fast, high efficiency, small size.
- PLC automatic program control, easy to operate, low failure rate.
- The baling position of carton is detected by imported photoelectric method, and can be done 1-3 times baling automatically.
- Single machine operation, also can be used with automatic packaging assembly line.

主要技术参数	
Model	DPP-50A
Conveying speed	6 cartons/min
Max carton size	L600×W500×H500mm
Min carton size	L200×W150×H150mm
Power	220V/380V 1φ-3φ 50-60Hz
Consumption	1000W
Air compressing	6kg/cm ³
Tape width	W48mm, 60mm, 72mm
PP belt width	W9, 12, 16, Thick0.5-1.0mm
Machine Dimension	L1620×W1420×H1550mm
Machine Weight	400kg



Manually push in → Manually folding → up and down sealing → Sealing finish → Auto Strapping Finish



▲DPP-50C Automatic folding, sealing and strapping machine

Product introduction:

Automatic folding, sealing and strapping machine can be used with automatic packing assembly line, automatic folding, up and bottom sealing tape, multiple baling, and realize unmanned packing. High work efficiency, widely used in toys, home appliances, printing, electronics, daily crystal and other mass production industries.

Product Feature:

- Sealing and baling at the same time, fast, high efficiency, small size.
- PLC automatic program control, easy to operate, low failure rate.
- The baling position of carton is detected by imported photoelectric method, and can be done 1-3 times baling automatically.
- Single machine operation, also can be used with automatic packaging assembly line.

主要技术参数	
Model	DPP-50C
Conveying speed	6 cartons/min
Max carton size	L600×W500×H500mm
Min carton size	L200×W150×H150mm
Power	220/380V 1φ-3φ 50-60Hz
Consumption	1200W
Air compressing	6kg/cm ³
Tape width	W48mm/60mm/72mm
PP belt width	W9, 12, 16, Thick0.5-1.0mm
Machine Dimension	L2460×W1880×H1520mm
Machine Weight	500kg



Manually push in → Auto folding → up and down sealing → Sealing finish → Auto Strapping Finish



- Using PLC control system, can improve the speed and accuracy of the machine.
- The machine can be used for unman strapping, or the whole strapping process can be controlled with single key, which is easy to use.
- According to the requirements of customers, 1-5 straps can be customized, the speed is 2.0 seconds/lane
- Unique aluminum alloy needle support, the latest mechanical structure, free oil.
- Electrical components made with international famous brand, the quality of the machine is stable and reliable.



▲ DEQ-200LA Automatic strapping machine



▲ DEQ-200HA Automatic strapping machine

▲ DPA-50+DPA-50T Automatic + -shape sealing machine

Product Feature:

- Adopt international advanced technology, and select imported parts, electrical components.
- Manually adjust the width and height of machine according to carton specifications, suitable for the same specification carton sealing at the same time.
- Carton sealing effect is beautiful, fast, save manpower, high efficiency.
- Simple operation, economical and durable, safe, minimum failure rate.

主要技术参数	
Model	DPA-50+DPA-50T
Carton size	L 150-500, W120-500, H120-500mm
Platform height	600mm (Can be customized)
sealing speed	600 - 720 cartons/hour
Machine Dimension	L2320*W2100*H1350mm
Power	220V 50-60Hz
Machine power	480W
Tape width	W48mm*1000 yard
Machine Weight	280kg

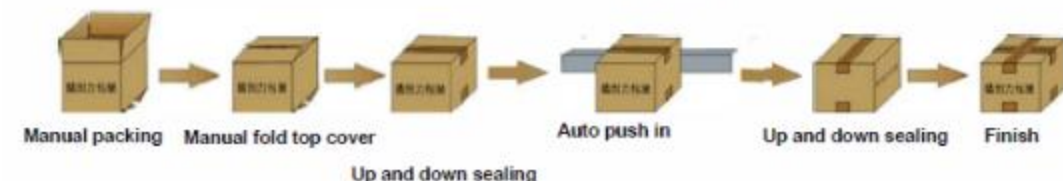

主要技术参数		
Model	DEQ-200LA	DEQ-200HA
Power	380V 50HZ	380V 50HZ
Power	1.6KW	1.6KW
Strapping speed	2.0Sec./Strap	2.0Sec./Strap
Bundle of tension	5-80kgs	5-80kgs
PP tape	(W):9-15mm, (Thick):0.5-1.0mm	(W):9-15mm, (Thick):0.5-1.0mm
Frame size	W800 x H600mm (Can be customized)	W800 x H600mm (Can be customized)
Packaging size	Min: W150*H100mm, Max:W700*H500mm	Min: W150*H100mm, Max:W700*H500mm
Machine size	L1900 x W630 x H1200mm	L1400 x W630 x H1430mm
Table height	480, 600mm (Can be customized)	750mm (Can be customized)
Machine weight	280kg	230kg



▲ DEQ-200H Automatic strapping machine

主要技术参数	
Model	DEQ-200HL
Power	380V 50HZ
Power	0.85KW
Strapping speed	2.0Sec./Strap
Bundle of tension	5-80kgs
PP tape	(W):9-15mm, (Thick):0.5-1.0mm
Frame size	W800 x H600mm (Can be customized)
Packaging size	Min:W80*H60mm, Max:W700*H500mm
Machine size	L1400 x W630 x H1430mm/L1900 x W630 x H1200mm
Table height	750/450mm (Can be customized)
Machine weight	180/230kg



▲ DPL-4535 + DPS-4525 Automatic L sealer and shrink machine

Product introduction:

Automatic L sealer and shrink machine is a fully automatic unmanned packaging line, feeding, bagging, sealing, cutting and shrinking are completed automatically. High efficiency, widely used in printing, color box, greeting card album, medicine, electronics, daily chemical, chemical crystal and other mass production industries.

Product Feature:

- The blade is made of imported special materials, the surface coating is made of dupont-teflon high-temperature resistant and anti-adhesion material, to ensure the sealing is not cracked and the middle line of the sealing is firm.
- Horizontal and vertical photoelectric, easy to switch, thin or small production, easy to complete the packaging.
- Automatic feeding, length can also be automatically adjusted through the combination of electric eye and timer, equipped with strange induction motor, automatic winding waste film.
 - When the size of the package is changed, the adjustment is very simple, no need to change the mold and bag maker.
- The blade is with automatic protection function, prevent accidental cutting package.
 - The sealer part is equipped with plexiglass protective cover and automatic alarm function, which greatly improves the operator's safety.
 - Sealing and cutting and thermal shrinkage packaging are completed automatically, with stable performance, great labor saving, reliable quality, high shrinkage efficiency and strong applicability.

主要技术参数

	DPL-4535	DPS-4825
Model	DPL-4535	DPS-4825
Power	1 φ220 50-60Hz	380V 50-60Hz
Power	2kw	8kw
Packing size	L+H≤500/W+H≤430mm	L500 × W400 × H200mm
Blade/Furnace chamber size	L500 × W450mm	L1200XW480XH250mm
Packing speed	1-25 pieces/min	20-40 pieces/min
Air compressor	5.5kg/cm ²	
Max current	10A	30A
Weight	250kg	115kg
Machine size	L1850 × W850 × H1550mm	L1600XW715XH1455mm



▲ DPL-5545D + DPS-5030L W Full automatic L vertical up and down sealer and shrink machine

Product introduction:

This machine is a new type of full automatic sealer and shrink machine, a high degree of automation, can automatically complete feeding, nesting, sealing and shrinking, can pack 20-35 pieces per minute. Support POF film, thermal shrinkage, automatic blowing film, thermal shrinkage packaging effect no wrinkle, without personnel to operate, high work efficiency.

Product Feature:

- The sealer tool is driven by the four-column vertical system, which can overcome the problem that the fold and sealing line of the traditional L sealer and shrink machine is not in the middle of the product.
- Photoelectric automatic adjusting height: the sealer height can be adjusted to ensure that the sealing line is in the middle position. Choosing the appropriate packaging height can reduce the travel time of the sealing knife and reduce the production cost.
- High degree of automation: automatic feeding, nesting, sealing and cutting, shrink and other steps, high automatic program control, simple and convenient operation, with safety furnace and alarm functions.
- Automatic L vertical up and down sealer and shrink machine is especially suitable for large products.

主要技术参数

	DPL-5545D	DPS-5030LW
Model	DPL-5545D	DPS-5030LW
Power	3φ 380V、50-60Hz	380V 50-60Hz
Power	5.5kw	16kw
Packing size	w+h≤450 w+L≤550 h≤230mm	L1500 × W450 × H250mm
Blade/Furnace chamber size	L550 × W450mm	L1500 × W500 × H300mm
Packing speed	20-35 pieces/min	20-60 pieces/min
Air compressor	5.5kg/m ²	
Max current	10A	32A
Weight	700kg	480kg
Machine size	L1850 × W1450 × H1410	L1850 × W1100 × H1250



DPL-5545C + DPS-5030LW Automatic side sealer and shrink machine

Product introduction:

This machine is on the basis of fully automatic high-speed side sealer machine according to the domestic market and the different needs of customers and design out a type medium speed automatic sealer machine, adopting photoelectric automatic detection was carried out on the product side, realizing the automatic unmanned packaging, high working efficiency, and can reach 30 pieces per minute, suitable for packaging of all kinds of different size and switch products.

Widely used in aluminum profiles, water pipes, printing, photo frames, electronics, daily chemicals, cosmetics and other mass production industries.

Product Feature:

- Precision accessories ensure the stability of the machine running at high speed.
- The height of sealing line can adapt to the height of packing.
- Horizontal sealing cutter adopts vertical system drive to ensure the sealing line is straight and strong.
- Wide range of packing, can pack a variety of different sizes and shapes of products
 - Adopt side sealing design, the product packaging length is unlimited.
 - The machine is equipped with safety protection measures, and the operation is more assured

主要技术参数

Model	DPL-5545C	DPS-5030 LW
Power	3φ 380V , 50-60Hz	380V, 50-60Hz
Power	3kw	16kw
Packing size	L(no limited)×W+H≤450mm H ≤170mm	L1500 × W450 × H250mm
Blade/Furnace chamber size	490mm	L1500 × W500 × H300mm
Packing speed	20-30pieces/min	20-60pieces/min
Air compressor	5.5kg/cm ²	
Max current	10A	30A
Weight	460kg	480kg
Machine size	L 1850 × W900 × H1550mm	L1850 × W1095 × H1325mm



▲ DPL-5545H + DPS-5030LW Automatic high speed side sealer and shrink machine

Product introduction:

This machine is suitable for full-automatic high-speed online shrink packaging, photoelectric automatic detection of production, the maximum packaging capacity is 60 pieces/min, suitable for packaging different sizes and shapes. Touch screen control machine, easy to adjust, and can store a variety packaging data, can be directly from the system when used, convenient and fast, greatly shorten the time when changing the packaging production.

Product Feature:

- Precision accessories ensure the stability of the machine running at high speed.
- The height of sealing line can adapt to the height of packing.
- The servo motor sealing cutter ensures the sealing precision and the sealing line is strong.
- The product packaging parameters can be stored in the system to quickly change the packaging products.
 - Wide range of packing, can pack a variety of different sizes and shapes of products.
 - The machine is equipped with safety protection measures and fault alarm function, so the operation is more assured.

主要技术参数

Model	DPL-5545H	DPS-5030LW
Power	3φ 380V , 50-60Hz	380V 50-60Hz
Power	3kw	16kw
Packing size	L(no limited) × W + H ≤ 450mm H ≤ 180mm	L1500 × W450 × H250mm
Blade/Furnace chamber size	L550 × W450mm	L1500 × W500 × H300mm
Packing speed	20-60pieces/min	20-60pieces/min
Air compressor	5.5kg/m ²	
Max current	10A	32A
Weight	700kg	480kg
Machine size	L2050 × W1580 × H1740mm	L1850 × W1095 × H1325mm

▲ DPL-6030+DPS-6040 Automatic sleeve type shrink packing machine



主要技术参数	
Model	DPL-6030
Packing speed	8-18 pieces/min
Packing size	L+W+H ≤ 700mm
Air compressor	6kg/m ³
Max current	10A
Blade size	700mm
Net weight	420kg
Power	2kw
Power	220/380V 3φ 50-60Hz
Machine size	L1360 x W2120 x H1900mm
Model	DPS-6040
Furnace chamber size	L1800 x W600 x H400mm
Packing size	L1500 x W550 x H330mm
Packing speed	20-60 pieces/min
Highest temperature	250°C
Machine weight	700kg
Most powerful	20kw
Power	220/380V, 3φ, 50-60Hz
Machine size	L2800 x W1100 x H1720mm

Product introduction:

Automatic sleeve type shrink packing machine adopt international advanced technology, which can be matched with automatic packing line to complete automatic unmanned packing, suitable for single product packing or multiple products combination packing with bottom support, such as carton, beer, beverage, chemical crystal packing and so on.

▲ DPL-6030Z+DPS-6040 Automatic Straight in cuff type shrink packing machine



主要技术参数	
Model	DPL-6030Z
Packing speed	8-22 pieces/min
Packing size	W+H ≤ 700mm
Air compressor	6kg/m ³
Max current	10A
Blade size	850mm
Net weight	465kg
Power	2kw
Power	220/380V 3φ 50-60Hz
Machine size	L1650 x W920 x H1895mm
Model	DPS-6040
Furnace chamber size	L1800 x W600 x H400mm
Packing size	L1500 x W550 x H330mm
Packing speed	20-60 pieces/min
Highest temperature	250°C
Machine weight	700kg
Most powerful	20kw
Power	220/380V, 3φ, 50-60Hz
Machine size	L2800 x W1100 x H1720mm

Product introduction:

- Adopt international advanced control components, stable and durable performance.
- The blade adopts the special design, the sealing is firm, does not crack, does not stick to the knife.
- Automatic feeding, pushing, film feeding, sealing and cutting.
- Stepless mechanical speed regulation, adjust the speed of feeding conveyor belt.
- Easy to operate, simple, the replacement of different specifications need 2-3 minutes.
- Feeding conveyor belt direction according to customer needs, design for left feeding or right feeding.
- Applicable PE shrink film.



▲ DPS-4825 Thermostatic shrink machine

主要技术参数	
Model	DPS-4825
Power	380V 50/60Hz 3 φ
Power	8kw
Packing speed	20-40 pieces/min
Highest temperature	250°C
Shrink tunnel size	L1200 x W480 x H250mm
Machine size	L1600 x W715 x H1465mm
Machine weight	115kg



▲ DPS-5030 Thermostatic shrink machine

主要技术参数	
Model	DPS-5030
Power	380V 50/60Hz 3 φ
Power	11kw
Packing speed	20-40 pieces/min
Highest temperature	250°C
Shrink tunnel size	L1500 x W500 x H300mm
Machine size	L1900 x W770 x H1600mm
Machine weight	185kg



▲ DPS-5030LW Thermostatic shrink machine

主要技术参数	
Model	DPS-5030LW
Power	380V 50/60Hz 3 φ
Power	16kw
Packing speed	20-60 pieces/min
Shrink tunnel size	L1500 x W600 x H400mm
Machine size	L1850 x W1095 x H1325mm
Machine weight	400kg

Product Feature:

- Suitable for fast transportation or storage.
- Strong adaptability, high efficiency and low consumption, reduce labor intensity.
- On the packaging can play a dustproof, moisture-proof,
- Reduce the surface scratch of the package, improve the surface quality, make the package more firm.

▲DPW-05 Full automatic pretension film winding machine

主要技术参数

Model	DPW-05
Turntable motor	0.75kw
Winding lifting motor	0.4kw
Power	220V 50Hz 20A
Machine size	L2545 x W1650 x H2400 mm
Max Package height	H2200mm
Max package weight	2000kg
Turntable diameter	1650mm
Machine weight	550kg

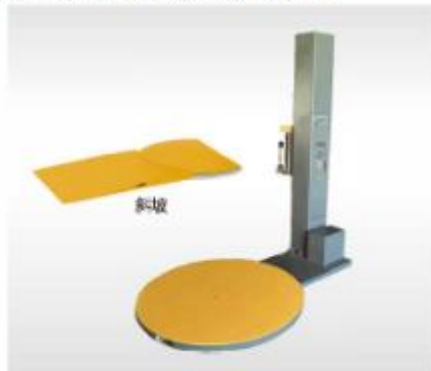

▲DPW-06 Full automatic on-line film winding machine

主要技术参数

Model	DPW-06
Turntable motor	0.75kw
Winding lifting motor	0.4kw
Power	380V, 50Hz
Machine size	L 12945 x W2000 x H2530mm
Max Package height	2100mm
Max package weight	2000kg
Turntable diameter	1500mm
Machine weight	600kg



▲DPW-08 Automatic up-breaking film winding machine

主要技术参数

Model	DPW-08
Power	380V 50-60Hz 2.5kw
Max Package size	L 1200 x W1200 x H1800/2400mm
Max package weight	2000kg
Machine size	L2545 x W1650 x H2280/2880mm
Turntable diameter	1650mm H 110mm
Turns	0-14 turns
Packing speed	20-40 pallets/hour



▲DCL-3030 Flat labeling machine

Product Feature:

Touch screen operating system, PLC control; Accurate label positioning, labeling accuracy up to $\pm 1\text{mm}$; Outgoing speed and transmission speed to keep pace, to ensure that the label does not wrinkle; If transparent label is used, special transparent eye option should be added. Machine made of stainless steel material, durable.

主要技术参数

Model	DCL-3030
label width	40-100mm
Package width/height	40-300mm/10-300mm
Labeling speed	12-25m/min
Label length	No limited
Label	Fold label/Coil label
Machine size	L1200 x W700 x H1400mm



▲DCL-500 Automatic double-sided labeling machine

产品简介:

The label head is driven by advanced servo motor, and all electric eyes are imported advanced photoelectric. PLC with man-machine interface control, labeling position, before and after, high and low can be adjusted. The labeling accuracy can reach $\pm 1\text{mm}$ (except for the error of the object and the label).

主要技术参数

Model	DCL-500
Labeling speed	0-25m/min
Product thickness	25mm-135mm
Product height	40mm-320mm
Power	2kW, AC220V/50Hz
Machine weight	about 400kg
Package weight	about 700kg
Machine size	L3000 x H1800 x W1600mm
Package size	L3100 x H1900 x W1800mm



Model	Degrees of freedom	Drive way	payload	Repeat positioning accuracy	Range of motion			
					有效负载 (kg)	重复定位精度 (mm)	J1	J2
RMD08	4	Ac servo drive	8	±0.08	±170	+90~-40	+68~-90	±360
RMD20	4	Ac servo drive	20	±0.08	±170	+115~-25	+70~-90	±360
RMD50	4	Ac servo drive	50	±0.2	±178	-40~+90	+78~-90	±360
RMD120	4	Ac servo drive	120	±0.3	±180	+100~-44	+121~-15	±360
RMD160	4	Ac servo drive	160	±0.3	±180	+100~-44	+121~-15	±360
RMD200	4	Ac servo drive	200	±0.3	±180	+100~-44	+121~-15	±360

Max speed				手腕允许负载惯量 (kg·m ²)	循环节拍 (回/小时)	运动半径 (mm)	本体重量 (kg)
J1	J2	J3	J4				
251	149	166	367.5	0.25	900 ^②	1413	180
140	140	150	330	0.51	\	1720	256
171	171	171	222	4.5	1700 ^②	2040	660
128	126	135	300	78	1560 ^②	3150	1500
123	123	128	300	78	1500 ^②	3150	1500
105	107	114	242	78	1300 ^②	3150	1500

According to user requirements, we can provide superior performance of the robot (Kuka, ABB, Kawasaki), as well as the robot automation application required fixture, logistics transmission line design and production.

Application: stacking, unstacking, handling, packing, stamping and loading of materials in the fields of electronics, electrical appliances, food, toys, lighting, beverage, chemical industry, etc.

▲ RMD08/RMD20

运动范围图

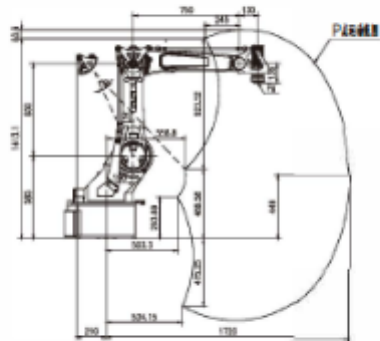

Range of motion diagram

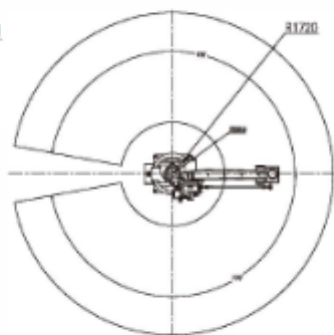

▲ RMD50

运动范围图

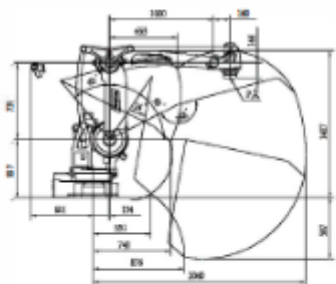

Range of motion diagram

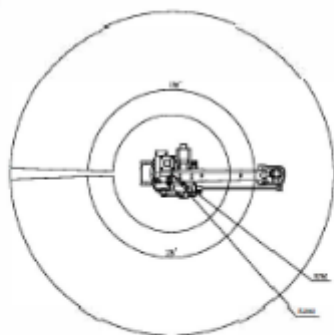

▲ RMD120/RMD160/RMD200

运动范围图

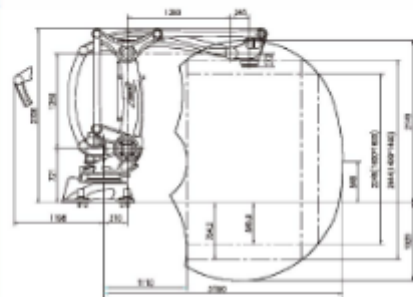

Range of motion diagram

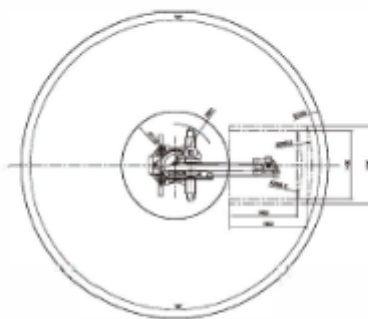

RMD08 / RMD20

RMD50

RMD120/RMD160/RMD200

Remark:

①The test track is height 150mm and width is 1000mm. The actual cycle time is affected by the actual working conditions.

②The test track is height 400mm and width is 2000mm. The actual cycle time is affected by the actual working conditions.

Avoid contact with flammable, explosive, corrosive gases and liquids;
Do not splash water, oil, dust; Keep away from electrical noise source (plasma).

▲ According to customers' requirements, we can provide a diversified supply of imported robots to meet customers' different needs.



Germany Kuka(4/6 axis)



Japan Kawasaki(4/6axis)

▲ Palletizing scheme of bagged package products



▲ Automatic packing assembly line scheme for carton packing products



▲ Palletizing scheme of bagged package products (flour)

Process description of the project: automatic sewing, flip bag, flattening/leveling, positioning, automatic palletizing mechanism of pallet warehouse, delivery in place, automatic palletizing by robot, and loading and unloading by heavy-duty conveying forklift truck. Kawasaki robot from Japan is optional. Total stacking speed of 2 production lines: 18 bags/min (2 bags 1 grasp, 1 put 1 bag).



▲ Automatic packing assembly line scheme for carton packing products. (Bottled oil) :

Process description: bottled after molding, products filling, material conveying and automatic unpacking, opening device, the robot packing, weighing out, metal detection to eliminate, labeling, H-shape sealing, conveying and tray under the library automatic tray, send in place, robot automatic palletizing, 3 pallet location after stacking principle overloading of the confluence feeding, automatic alarm into online winding, pallet was completed, forklift truck load.

Select German Kuka robot. Total packing speed of 3 production lines: 21 boxes/min, 3 boxes/grab stacking.



▲ Carton packing product packing line project (carton mask):

Robot packing, robot putting upper and lower paper pad, weighing elimination, box sealing, cross turning, H-shape box sealing, upper and lower labeling, code spraying, positioning of conveying arrangement, robot stacking, stacking completion alarm, forklift carrying away.

Kawasaki robot from Japan is optional. Maximum packing speed for 3 production lines: 9 cases/min, 1 case/grab stacking.

