

单机系列 SINGLE MACHINE

- 02 尖锥滚圆机
Conical rounder
- 03 面团分割输送机
Dough divider elevator
- 05 面团分块滚圆机
Dough divider rounder
- 09 面团分块机
Dough divider
- 11 面团切块机
Dough cutter
- 13 中间醒发机
Intermediate proofer
- 15 汉堡整形机
Burger buns molder
- 16 汉堡热狗整形机
Burger/Hot dog buns moulder

- 17 吐司整形机
Long loaf bread moulder
- 19 法棍整形机
Baguette bread moulder
- 20 撒芝麻燕麦机
Sesame duster

生产线系列 PRODUCTION LINE

- 22 汉堡成型线
Burger buns forming line
- 23 热狗成型线
Hot dog buns forming line
- 25 吐司成型线
Long loaf bread forming line
- 26 法棍成型线
Baguette bread forming line
- 27 墨西哥饼面团成型线
Tortilla forming line
- 28 冷冻面团成型线
Frozen dough balls line



单机系列 SINGLE MACHINE

- | | |
|---------|-----------------------------|
| 尖锥滚圆机 | Conical rounder |
| 面团分割输送机 | Dough divider elevator |
| 面团分块滚圆机 | Dough divider rounder |
| 面团分块机 | Dough divider |
| 面团切块机 | Dough cutter |
| 中间醒发机 | Intermediate proofer |
| 汉堡整形机 | Burger buns moulder |
| 汉堡热狗整形机 | Burger/Hot dog buns moulder |
| 吐司整形机 | Long loaf bread moulder |
| 法棍整形机 | Baguette bread moulder |
| 撒芝麻燕麦机 | Sesame duster |

锥形滚圆机 Conical rounder

应用场景:适用于吐司、法棍等大克重面团的揉圆;

Application:
Use for rounding large-gram dough such as toast and baguette.

产品特点/Feature

- 01 搓圆轨道带特氟龙防粘涂层, 防止面团揉圆时粘连;**
Teflon coated channels and cone, keep them clean.
- 02 设计坚固, 结构耐用, 节约维护成本;**
Solid design and durable construction help to ensure minimal maintenance.
- 03 锁定脚轮可让您轻松将设备固定到位以进行生产;**
Casters allow you easily secure the unit in place for production.
- 04 操作面板人性化, 可以从机器两侧轻松操作;**
Operation panel easily accessible from both sides.
- 05 搓圆轨道角度可调, 以适应不同重量之面团;**
Rounding angle is adjustable, to fit different dough balls.



型号 Model	重量范围 Weight range	最大产能 Max capacity	外形尺寸(mm) Overall size
YSN-YQ800	1-1000g	1900-7600psc/h	1060*1060*1500

*Note: Customizable large dough chunking/dividing.

面团分割输送机

Dough divider elevator

★接受非标定制
Accept non-standard customization

应用场景: 向高处自动输送面团, 节约人工成本

Application: Divide and feed dough automatically, labor saving.

产品特点/Feature

- 01 配有镀特氟龙三角切刀, 分切过程不伤面筋, 保留面团原始组织结构;
Triangle knives make it possible to divide dough without gluten damage, keep the original flavor.
- 02 非定量分割, 分切速度可调, 向下一台机器送料;
Feed next process automatically, working speed adjustable, without weighting system.
- 03 每次分切得到一块大面团;
Get one dough piece with one action.

型号 Model	料斗容量 Hopper volume	出料示意图 Discharge method	面团重量 Weight	外形尺寸(mm) Overall size
YSN-SC200	200kg		6.0-8.0 Kg	3400*1100*2550
YSN-SC400	400kg		12.0-15.0 Kg	1880*1533*3550
YSN-SV200	300kg		-	4000*1500*2300

备注: QLSV-300为单螺杆真空面泵, 连续出料。

Remark: QLSV-300 is the vacuum drive type divider, feeding continuously.

YSN-SC200/YSN-SC400
Application Scene

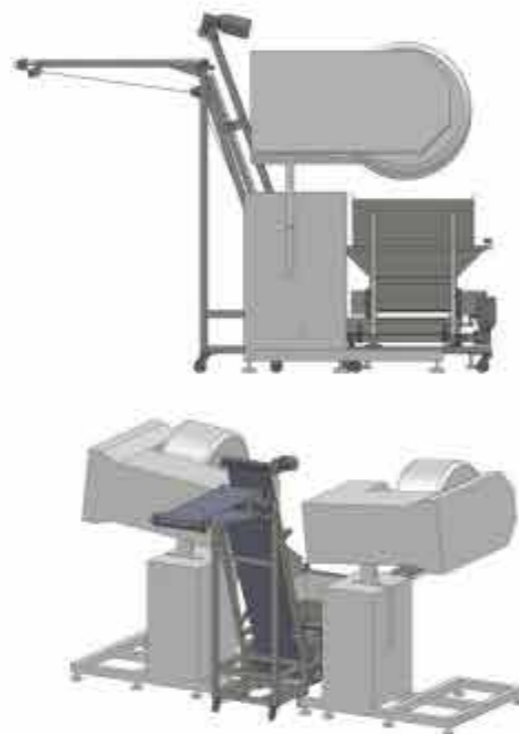
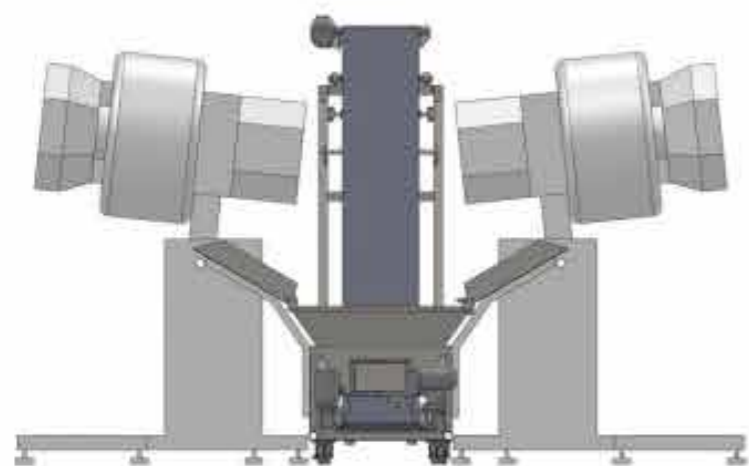

YSN-SC200/YSN-SC400



单螺杆真空面泵YSN-SV300

面团分块滚圆机

Dough divider rounder

★接受非标定制
Accept non-standard customization

NO OIL, NO MESS, SAVES MONEY!

YSNYQ系列

产品特点/Feature

- 01 体积式分块系统, 不伤面筋;
Volumetric type dividing system, won't hurt gluten.
- 02 可处理软-中等硬度的面团;
Suitable to work softy and semi-hard dough.
- 03 面团克重调节系统, 简单易操作;
Manual weighting system, easy to operate.
- 04 滚圆筒喷有特氟龙不粘涂层, 节约清洁时间;
Teflon coated rounding drum, make it's easy for clean-up.
- 05 顶部料斗容量35kg面团;
Top hopper volume 35Kg.
- 06 无油定量分块, 无需润滑油。
Oil free dividing system, helps to save cost.



YSN-YQ2



YSN-YQ3



YSN-YQ4



YSN-YQ5



YSN-YQ6



YSN-YQ8



YSN-YQ9

QLDR系列	型号 Model	面团克重 Weight range	出料示意图 Discharge method	最大产能 Max capacity	外形尺寸(mm) Overall size
工业版 Heavy duty type	YSN-YQ2	150-350g	●●	4000pcs/h	2100*1200*1800
	YSN-YQ3	130-250g	●●●	6000pcs/h	2100*1200*1800
	YSN-YQ4	28-200g	●●●●	8000pcs/h	2100*1200*1800
	YSN-YQ5	28-130g	●●●●●	10000pcs/h	2100*1200*1800
	YSN-YQ6	28-130g	●●●●●●	12000pcs/h	2100*1200*1800
	YSN-YQ8	28-110g	●●●●●●●●	16000pcs/h	2100*1330*1800
	YSN-YQ9	28-75g	●●●●●●●●●●	18000pcs/h	2100*1330*1800

适合的面团含水量50-65%, 以中筋面粉100kg为基准计算。
Suitable dough water content 50-65%, base on 100kg plain flour.

YSNMS系列

产品特点/Feature

- 01 体积式分块系统, 不伤面筋;
Volumetric type dividing system, won't hurt gluten.
- 02 可处理软-中等硬度的面团;
Suitable to work softy and semi-hard dough.
- 03 面团克重调节系统, 简单易操作;
Manual weighting system, easy to operate.
- 04 滚圆筒喷有特氟龙不粘涂层, 节约清洁时间;
Teflon coated rounding drum, make it's easy for clean-up.
- 05 顶部料斗容量20kg面团;
Top hopper volume 20Kg.
- 06 无油定量分块, 无需润滑油。
Oil free dividing system, helps to save cost.



YSN-MS2



YSN-MS3



YSN-MS4

QDMS系列	型号 Model	面团克重 Weight range	出料示意图 Discharge method	最大产能 Max capacity	外形尺寸(mm) Overall size
经济版 Economical version type	YSN-MS2	28-200g	● ●	3000pcs/h	1340*870*1650
	YSN-MS3	28-130g	● ● ● ●	4500pcs/h	1340*870*1650
	YSN-MS4	28-180g	● ● ● ● ● ●	6000pcs/h	1340*1070*1650
	YSN-MS5	28-130g	● ● ● ● ● ● ● ●	7500pcs/h	1340*1070*1650
	YSN-MS6	28-110g	● ● ● ● ● ● ● ● ● ●	9000pcs/h	1340*1070*1650
适合的面团含水量55-65%, 以中筋面粉100kg为基准计算。 Suitable dough water content 55-65%, base on 100kg plain flour.					

工业版YSNYQ和经济版YSNMS的区别

The difference between Heavy duty machine and Light duty ones.

分块推面系统:

工业版:兼容50-65%含水量软-硬面团。

经济版:兼容55-65%含水量软面团。

Divide pushing system

YSNDR: Fit 50-65% water content soft-hard dough.

YSNMS: Fit 55-65% soft dough.



YSN-MS5



YSN-MS6

面团分块机

Dough divider

应用场景：用于吐司、法棍等大面团的成型。

Application:
Use for loaf toast & long baguette bread dough balls dividing.



★接受非标定制
Accept non-standard customization



产品特点/Feature

- 01 无油分块系统, 无需使用任何润滑油脂即可实现定量分块;**
Oil free dividing system, the lubricating oil is un-necessary.
- 02 可处理软-中等硬度面团, 不伤面筋;**
It's possible to handle soft to middle hard dough, and won't hurt dough gluten.
- 03 电动克重调节系统, 面团重量精准, 误差3%以内;**
Automatic dough weighting system, weight error is less than 3%.
- 04 向尖锥滚圆机自动送料, 以实现面团的自动分块搓圆;**
Feed dough to conical rounder, to realize the dividing rounding of big dough balls.

特点 Feature	型号 Model	分块重量 Weight range	出料示意图 Discharge method	最大产能 Max capacity	外形尺寸(mm) Overall size
经济版 Economical version type	YSN-MD1	400-800g	■	1500 pcs/h	1100*1070*1650
	YSN-MD2	200-400g	■ ■	3000 pcs/h	1100*1070*1650
	YSN-MD3	100-300g	■ ■ ■	4500 pcs/h	1100*1070*1650
	YSN-MD4	30-200g	■ ■ ■ ■	6000 pcs/h	1100*1070*1650
适合的面团含水量55-65%, 以中筋面粉100kg为基准计算。 Suitable dough water content 55-65%, base on 100kg plain flour.					
工业版 Heavy duty type	YSN-LD1	500-1000g	■	2000 pcs/h	1300*1200*1800
	YSN-LD2	200-500g	■ ■	4000 pcs/h	1300*1200*1800
	YSN-LD3	100-300g	■ ■ ■	6000 pcs/h	1300*1200*1800
适合的面团含水量50-65%, 以中筋面粉100kg为基准计算。 Suitable dough water content 50-65%, base on 100kg plain flour.					

面团切块机

Dough cutter





★接受非标定制
Accept non-standard customization

应用场景:向输送机或分块滚圆机自动送料,节约人工成本。

Application:
Feed the dough lifter or divider rounder automatically, labor saving.

产品特点/Feature

- 01 配有不锈钢三角切刀,分切过程不伤面筋,保留面团原始组织结构;
SUS304 Triangle knives make it possible to divide dough without gluten damage, keep the original flavor.
- 02 非定量分割,分切速度可调,向下一台机器送料;
Feed next process automatically, working speed adjustable, without weighting system.
- 03 每次分切得到一块大面团;
Get one dough piece with one action.

型号 Model	料斗容量 Hopper volume	出料示意图 Discharge method	面团重量 Weight	外形尺寸(mm) Overall size
YSN-LC120M	120kg		6-8kg	850*850*1000
YSN-LC200	200kg		8-10kg	1360*1040*830
YSN-LC300H	300kg		13-15kg	1560*1400*2850
YSN-LC400	400kg		16-20kg	1900*1550*880
YSN-LBV300	300kg	真空驱动连续出料 Vacuum feeding	用于去除面团内气体 Aim to release inner air	

型号(Model): YSN-LC300H



型号(Model): YSN-LBV300



中间醒发机

Intermediate proofer

中间醒发机旨在根据不同用户的需求,让圆形面团在预设时间进行静置,达到面筋松弛目的。

Intermediate proofer is designed to take dough gluten rest before molding.

产品特点/Feature

- 01 全304不锈钢结构,食品安全更有保障;**
Fully SUS304 stainless steel structure, ensure food safety.
- 02 采用西门子PLC控制器,自动调节箱内温湿度;**
With Siemens PLC controller, adjust inner temperature and humidity automatically.
- 03 透视板装置,可直接观察到料篮在机器内的运作状况;**
With transparent windows, the running process is visible.
- 04 设备的自动运行与分割机速度同步,以确保连续的生产过程;**
Automatic continuous work synchronized with the divider speed.
- 05 经过充分松弛后,面团整形过程中不易收缩变形;**
With enough resting, dough buns won't shrink during molding process.



YSN-T230
中间醒发机-墨西哥饼

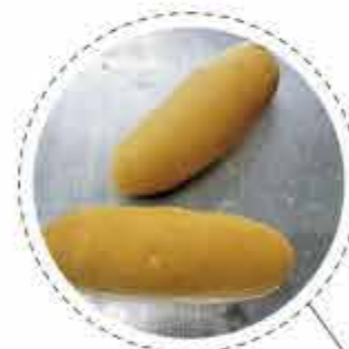

型号 Model	产品 Products	醒发时间 Resting time	料篮数量 Pocket quantity	面团克重 Dough weight range	最大产能 Max Capacity	外形尺寸(mm) Overall size
YSN-T230	墨西哥饼 Tortilla	8-12 Mins	230*6	28-130g	12000 pcs/h	6200*1069*3500
YSN-H175	热狗 Hot dog	6-8 Mins	175*6	28-200g	9000 pcs/h	4300*1100*2860
YSN-T872	吐司 Toast 法棍 Baguette	8-12 Mins	72*8	200-1500g	4000 pcs/h	2100*1840*3100

备注:松弛时间以及每排料篮数量需依工艺要求确定,详询我司业务人员。

Remark: Resting time and pocket quantity both are customized according to process demands, for exactly information, please contact us.



YSN-H175
中间醒发机-热狗汉堡



YSN-TB72
中间醒发机-吐司法棍

翻缸式和面机

Bowl tilting lift spiral mixer

应用场景:用于面包工厂面粉的搅拌;

Application:

Used for mixing flour in a bakery factory



产品特点/Feature

- 01** 采用翻缸式设计倒出面团, 省时省力。
Uses a tilting design for easy dough removal, saving time and effort.
- 02** 整体设计采用超厚钣金焊接, 美观耐用。
Features an ultra-thick sheet metal welding design, beautiful and durable.
- 03** 超大功率设计, 进口元件, 动力强劲, 机械耐用度高。
Powerful design with imported components, high durability.
- 04** 电路具有过载保护功能, 可避免因操作故障而损坏设备。
Circuit has overload protection to prevent damage due to operational errors.

型号 Model	搅拌桶直径 Bowl diameter	翻起高度 Total height	和面限量 Max capacity	外形尺寸(mm) Overall size
YSN-75F	750mm	1.8m	75kg	1466*1467*1415mm
YSN-100F	840mm	1.9m	100kg	1551*1608*1454mm
YSN-125F	900mm	1.99m	125kg	1600*1698*1521mm
YSN-150F	1000mm	2m	150kg	1690*1708*1520mm

离缸式和面机

Bowl removable spiral mixer



产品特点/Feature

- 01** 采用离缸式设计推出面团, 方便周转。
It adopts a bowl removable design to push out the dough, which facilitates turnover.
- 02** 机身采用不锈钢板材制作, 易清洗, 不生锈。
The body is made of stainless steel plate, which is easy to clean and does not rust.
- 03** 高效搅拌, 面团吸水膨胀性高, 节省生产成本。
Efficient mixing, the dough has high water absorption and expansion, saving production costs.
- 04** 电路具有过载保护功能, 可避免因操作故障而损坏设备。
Circuit has overload protection to prevent damage due to operational errors.

型号 Model	搅拌桶直径 Bowl diameter	抬起外型尺寸 Raised Dimensions	和面限量 Max capacity	外形尺寸(mm) Overall size
YSN-L100	840*500mm	2040*1109*1789mm	100kg	1896*1109*1444mm
YSN-L125	900*530mm	2123*1207*1870mm	125kg	1976*1207*1446mm
YSN-L150	900*530mm	2145*1307*1870mm	150kg	2176*1307*1446mm

吐司整形机

Long loaf bread moulder

★接受非标定制
Accept non-standard customization

应用场景：吐司方包，短法棍、长法棍面包的整形。

Application:
Forming for Toast bread, long loaf bread, Baguette bread.

产品特点/Feature

01 全不锈钢SUS304结构, 压辊材质为食品级工程塑料;

Fully SUS 304 structure, pressure rollers are made of food-grade plastics;

02 重型不锈钢辊轮, 排出面团内部空气;

Heavy-duty stainless steel rollers help release the air trapped inside the dough;

03 可对接自动排盘装置, 实现全自动操作;

It's possible to cooperate with automatic panning system, realize unmanned operation.

04 可对接二次整形装置, 实现二次排气整形;

Can connect the 2nd molding station, to realize two times air exhausting.

05 轨道压板可实现面团长度定量控制, 并使得表面光滑;

Pressure plate helps to control dough stick length, and get smooth surface.



吐司整形机YSN-TS300

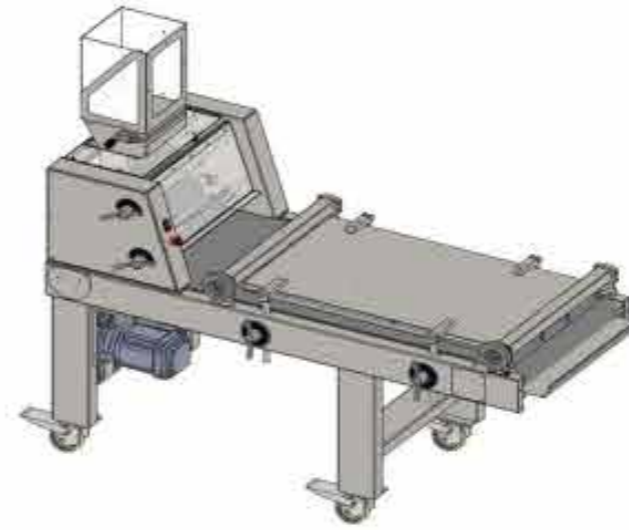

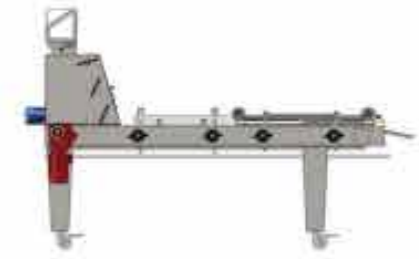
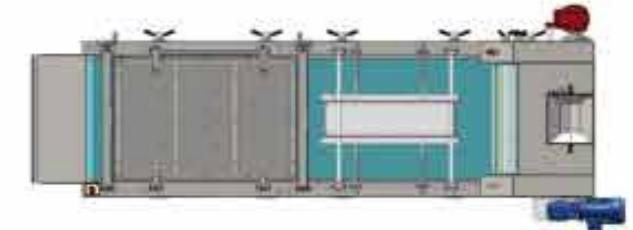
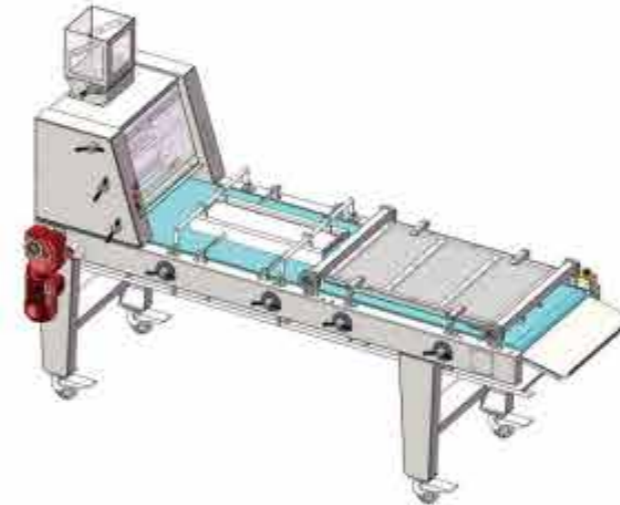

吐司整形机YSN-TS881

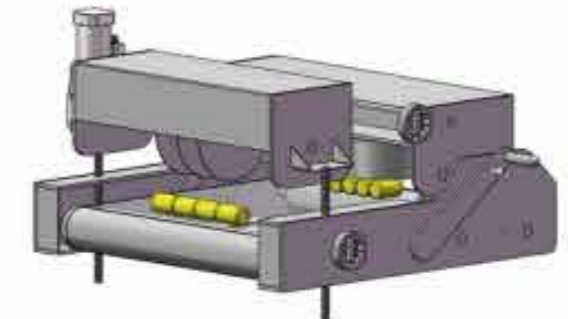
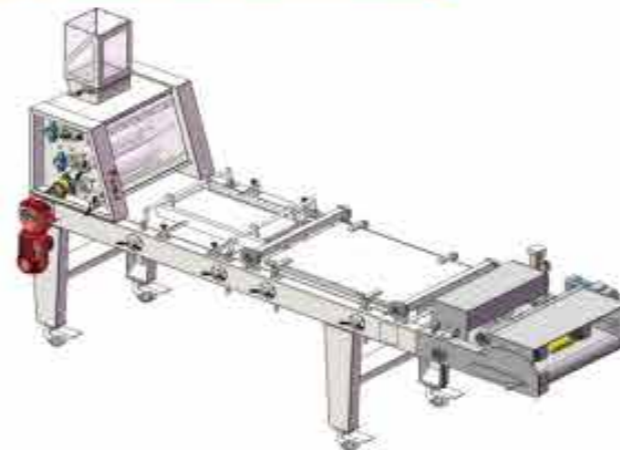

吐司整形机YSN-TS882



型号 Model	特点 Feature	最大产能 Max capacity	最大整形长度 Max Shaping Length	出料示意图 Discharge method	外形尺寸(mm) Overall size
YSN-TS300	2道辊 2 rollers	3000 pcs/h	300mm		1370*1025*2025
YSN-TS881	3道辊 3 rollers	3000 pcs/h	600mm		3150*1065*2025
YSN-TS882	3道辊 3 rollers with cutting 配有分切刀	3000 pcs/h	600mm		3650*1065*2025

法棍整形机

Baguette bread moulder

★接受非标定制
Accept non-standard customization

应用场景:用于面包厂法棍面包的整形;
Application:
Use for baguette molding for bakery factory.



产品特点/Feature

- 01 不锈钢网链防止面团跑偏;
Curl chain helps centering dough stick.
- 02 帮助有效整形面团形状与结构;
Help define the shape and structure of Baguette dough.
- 03 直径、长度一致性高, 面团表面光滑;
With high Length & Diameter consistency, and smooth surface.
- 04 搭配生产线提高生产率, 降低人工成本;
Match production lines to increase productivity while reducing labor costs.

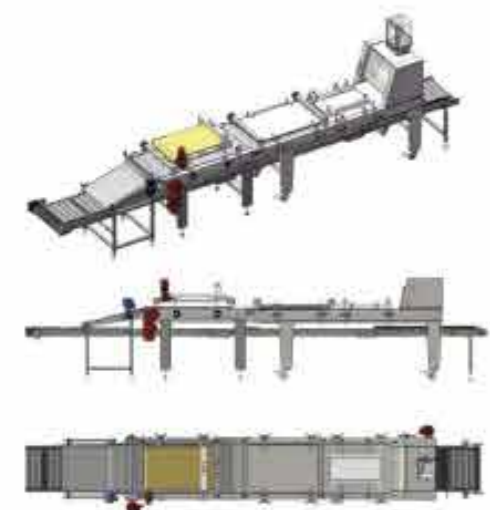

型号 Model	法棍尺寸 Baguette Size	重量范围 Weight range	出料示意图 Discharge method	最大产能 Max capacity	外形尺寸(mm) Overall size
YSN-FM750	300-600mm	200-1000g		3000 pcs/h	6100*1000*1900

撒芝麻燕麦机

Sesame duster



应用场景:
与成型线对接, 醒发前撒芝麻。
与隧道炉对接, 醒发后撒芝麻。

Application:
Connect with forming line, dusting before fermentation.
Connect with tunnel oven, dusting after fermentation.

产品特点/Feature

- 01 配进口水雾化喷头及撒粉电机;
Equipped with high quality water spray nozzles and dusting motor.
- 02 简洁按钮控制, 撒芝麻速度可调;
Button control, dusting speed is adjustable.
- 03 具有自来水过滤装置;
Equipped with a water filter.
- 04 可选配水刀装置;
It's possible to equip water jet.



功能描述 Description	产品特点 Feature	型号 Model	最大产能 Max Capacity	外形尺寸(mm) Overall size
撒芝麻 Sesame dusting	5道口 5-Rows	YSN-04-5S	10,000pcs/h	2320*1150*1350
撒燕麦 Oat dusting		YSN-04-5O		
撒芝麻和燕麦 Both sesame and oat dusting		YSN-04-5SO		
撒芝麻 Sesame dusting	6道口 6-Rows	YSN-04-6S	12,000pcs/h	
撒燕麦 Oat dusting		YSN-04-6O		
撒芝麻和燕麦 Both sesame and oat dusting		YSN-04-6SO		

生产线
PRODUCTION LINE

- 汉堡成型线 Burger buns
- 热狗成型线 Hot dog buns
- 吐司成型线 Long loaf bread
- 法棍成型线 Baguette bread
- 墨西哥饼面团成型线 Tortilla
- 冷冻面团线 Frozen dough balls

汉堡成型线 Burger buns forming line

★接受非标定制
Accept non-standard customization

应用场景：适用于汉堡工厂汉堡胚的成型与制作；

Application: Suitable for mid-big bakery factory with burger buns production.

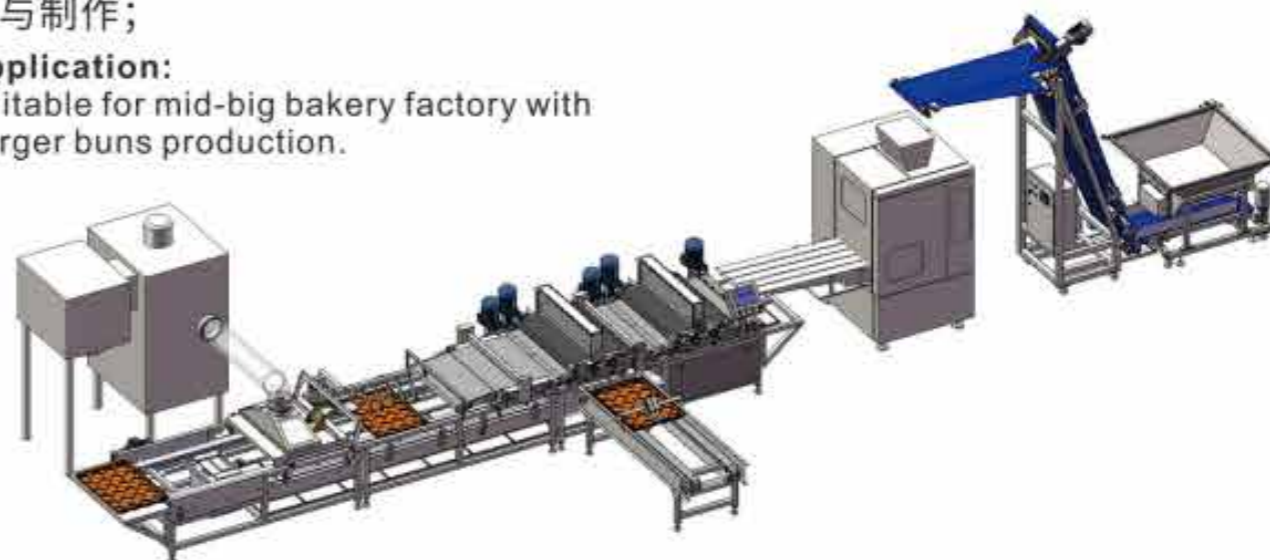

- 01 面团式汉堡胚成型线, SUS304不锈钢结构;
Volumetric type burger buns forming line, SUS304 main structure.
- 02 PLC智能控制, 保护机器及操作者人身安全;
PLC intelligent control protects the personal safety of the machine and the operator.
- 03 分块精准, 搓圆效果好, 不伤面筋;
With high division accuracy and good round shape. Won't damage the dough gluten.
- 04 最大产能每小时10,000个到24,000个;
Max capacity 10,000- 24,000 pcs/h with one line.

型号 Model	重量范围 Weight range	出料示意图 Discharge method	最大产能 Max capacity	外形尺寸(mm) Overall size
YSN-B5	28-130g		10,000 pcs/h	11050*1300*2500
YSN-B6	28-130g		12,000 pcs/h	11050*1440*2500
YSN-B24	28-100g		24,000 pcs/h	11000*1500*2800



热狗成型线

Hot dog buns forming line

★接受非标定制
Accept non-standard customization

应用场景:可兼容汉堡热狗的成型生产;
Application:
Compatible with the molding of burgers and hot dogs.

单线 Single line
YSN-C6



产品特点/Feature

- 01 可切换模式, 自主选择汉堡或热狗制作;
It's possible to produce both hot dog and burger buns by model switch.
- 02 尺寸型号不唯一, 根据客户需求定制;
The forming process can be customized according to demands.
- 03 面团分块精度高, 减少原材料损失;
Saving of raw materials due to high weight accuracy of the dough balls.
- 04 每台机器均配有感应装置, 保障生产线的连续性;
Each machine is equipped with an induction device to ensure the continuity of the production line.

型号 Model	热狗尺寸 Hotdog Size	重量范围 Weight range	出料示意图 Discharge method	最大产能 Max capacity	外形尺寸(mm) Overall size
单线 Single line YSN-H6	6 inch	28-130g		6,000 pcs/h	15000*1440*2800
	8 inch	28-130g		4,500 pcs/h	15000*1440*2800
双线 Double line YSN-H8	6 inch	28-130g		12,000 pcs/h	18000*4200*3500
	8 inch	28-130g		9,000 pcs/h	18000*4200*3500

单线 Single line
YSN-H6

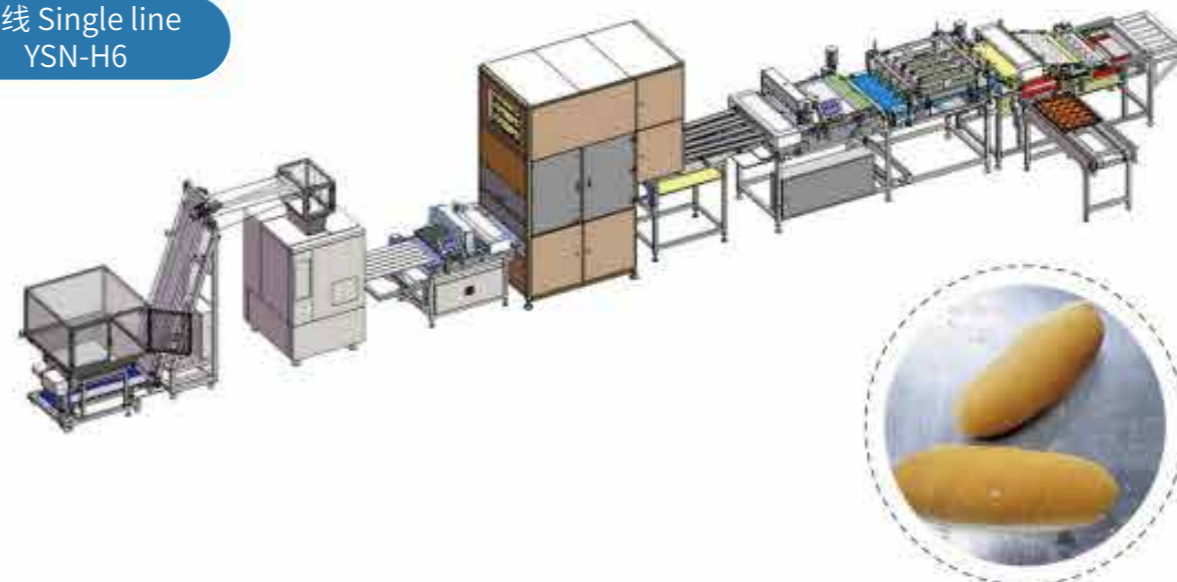

双线 Double line
YSN-H8



吐司成型线

Long loaf bread forming line

★接受非标定制
Accept non-standard customization

应用场景: 吐司方包, 短法棍、长法棍面包自动化成型。

Application:
Automatic forming for Toast bread, long loaf bread, Baguette bread.

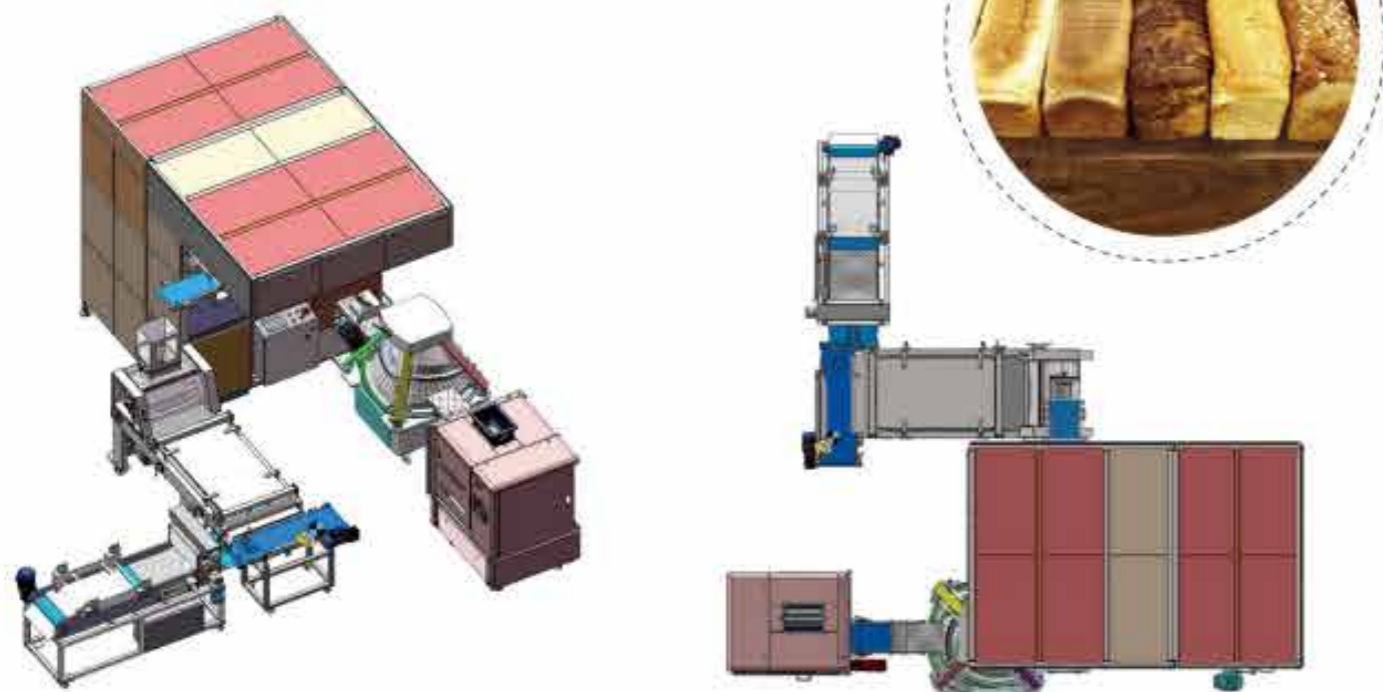

产品特点/Feature

- 01 体积式分块结构, 克重误差小, 保留面团原始气孔组织;
Volumetric dividing method, helps to get smaller error and good dough inner structure.
- 02 面团重量、松弛时间、整形状态均可调;
Dough balls weight, resting time, molding process are all adjustable.
- 03 整线自动控制, 可整线联机, 也可单机独立工作;
Whole line work in LINKED model, also viable in independent model ;
- 04 提高生产效率, 节省劳动力, 减少生产成本。
Increase production efficiency, save labor, and reduce production costs.

型号 Model	面团克重 Dough weight range	出料示意图 Discharge method	最大产能 Max capacity	机器尺寸(mm) Overall size
YSN-T3	50-1000g		3000pcs/h	8500*5000*2600

法棍成型线

Baguette bread forming line

★接受非标定制
Accept non-standard customization

应用场景: 用于高产能长法棍生产需求的烘焙工厂;

Application:
Use for long baguette forming with High production demands bakery.

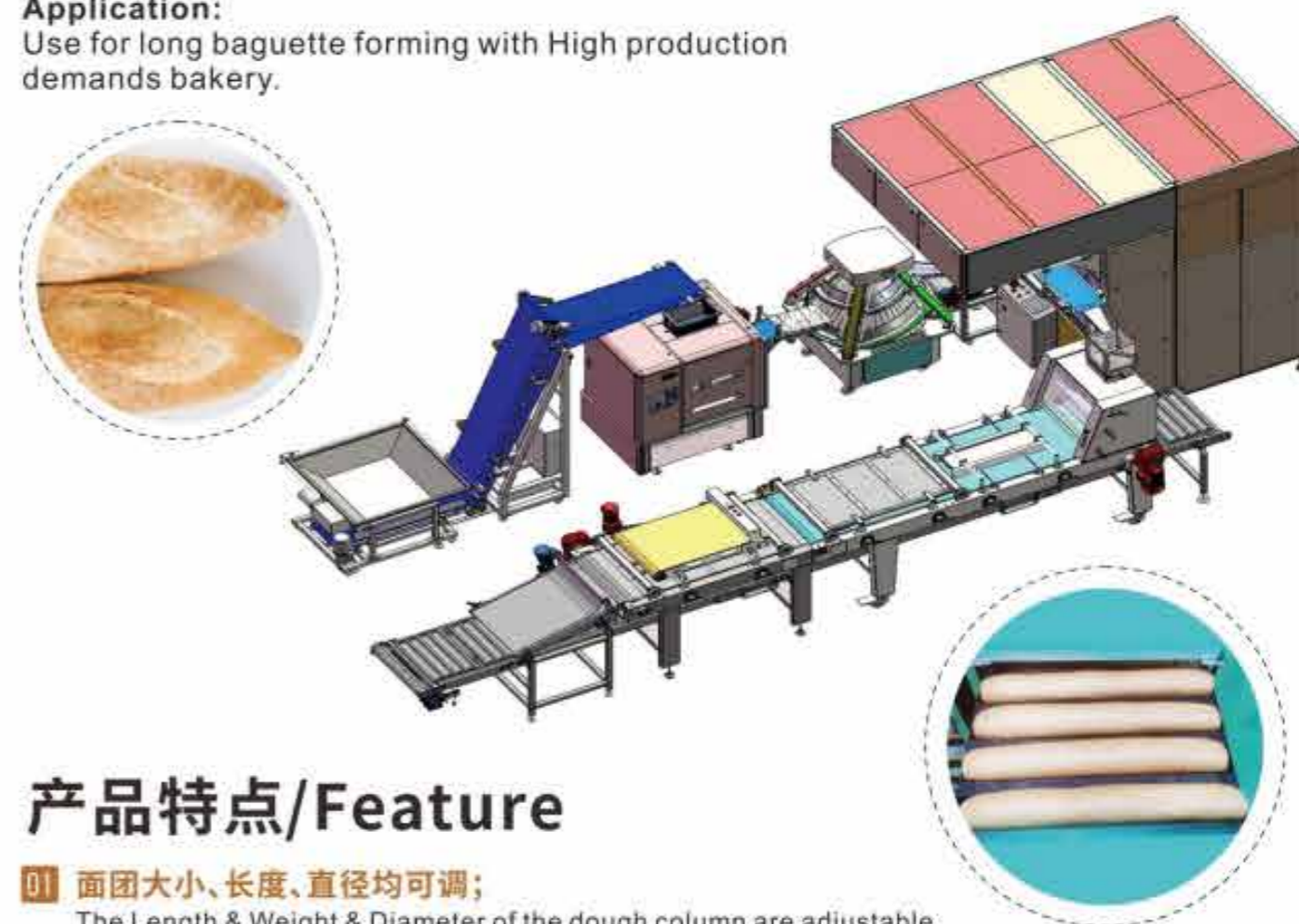

产品特点/Feature

- 01 面团大小、长度、直径均可调;
The Length & Weight & Diameter of the dough column are adjustable.
- 02 中间醒发机最大程度释放面筋压力, 避免整形后收缩;
With a intermediate proofer, it's possible to release gluten pressure.
- 03 整线运行稳定, 操作简单, 节约人工;
Easy to operate with stable running, and labor saving.
- 04 可选配自动进盘排盘线或自动回盘线;
It's possible to connect the Auto tray feeding & panning line or tray returning line.

型号 Model	法棍尺寸 Baguette Siz	重量范围 Weight range	出料示意图 Discharge method	最大产能 Max capacity	外形尺寸(mm) Overall size
YSN-F3	300-600mm	200-1000g		3000pcs/h	10000*4000*2800

墨西哥饼面团成型线

Tortilla forming line

★接受非标定制
Accept non-standard customization

应用场景:用于墨西哥饼面团成型;

Application:
Use for tortilla dough balls forming.

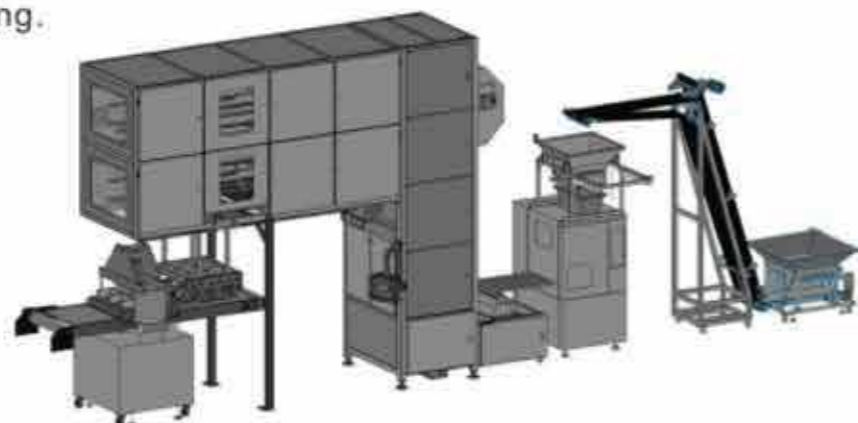

产品特点/Feature

- 01 一条产线可以满足多种墨西哥饼尺寸;
A production line can meet various tortilla sizes demands.
- 02 改变滚圆筒以得到不同克重面团;
Easy to realize different dough ball weight by change outer rounding drum.
- 03 醒发时间8-12分钟可调;
Resting time 8-12 minutes adjustable.
- 04 可根据客户需要扩大产能,提高生产效率;
Can be expanded according to customer needs to improve production efficiency.

型号 Model	墨西哥饼尺寸 Tortilla Size	出料示意图 Discharge method	最大产能 Max capacity	外形尺寸(mm) Overall size
YSN-T6	8 inch		3600 pcs/h	11000*1500*3500
	10 inch		900 pcs/h	
	12 inch		900 pcs/h	
YSN-T8	8 inch		8000 pcs/h	11000*1500*3500
	10 inch		3600 pcs/h	
	12 inch		3600 pcs/h	

冷冻面团成型线

Frozen dough balls line

★接受非标定制
Accept non-standard customization

应用场景:适用于披萨/冷冻面团/餐包/汉堡等产品的面团成型;

Application:
Suitable for Pizza/ Frozen dough balls/ brioche/ burger buns production.



产品特点/Feature

- 01 冷冻面团生产线满足各种面团重量需求,速度可调;
Frozen dough ball line available for a variety of weights, speed adjustable.
- 02 配备理料装置,使面团排列整齐;
Equipped with a sorting device to make the dough arrange neatly.
- 03 面团进盘与排盘协调同步,自动落盘排盘;
Equipped with the tray feeding and panning synchronization system.
- 04 最大产能每小时10,000个到12,000个;
Max capacity 10,000- 12,000 pcs/h with one line.

型号 Model	重量范围 Weight range	出料示意图 Discharge method	最大产能 Max capacity	机器尺寸(mm) Overall size
YSN-B5	28-130g		10000pcs/h	8000*1300*2500
YSN-B6	28-130g		12000pcs/h	8000*1300*2500

隧道炉冷却塔生产线

Baking and Cooling Production Line

应用场景:用于食品工厂的烘烤和自动冷却;

Application:

It is suitable for baking and automatic cooling processes in food factories.

产品特点/Feature

- 01 全自动化连续生产, 生产效率高, 产量大。
Fully automated continuous production, high efficiency, and large output.
- 02 自动化进出, 节省使用空间, 无需人工, 降低成本。
Automated entry and exit, saves space, requires no manual labor, and reduces costs.
- 03 全自动化控制, 不同产品的温度和时间可以灵活调节。
Fully automated control, allowing flexible adjustment of temperature and time for different products.
- 04 生产线长度和宽度可以根据产量大小灵活定制。
Production line length and width can be customized flexibly based on production volume.

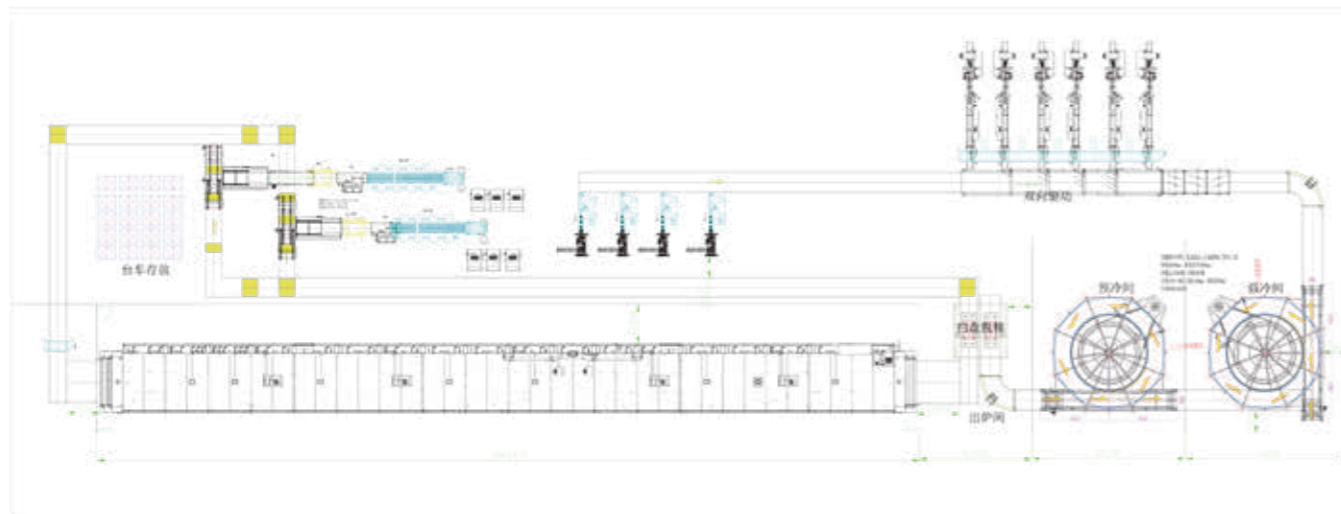

型号 Model	内腔尺寸 Internal Dimensions	烘烤高度 Baking height	出料示意图 Discharge method	能源 Energy	外形尺寸(mm) Overall size
YSN-S14Q	W1400*H800mm	220mm	■ ■	Gas	W2300*H1600mm
YSN-S20Q	W2000*H800mm	220mm	■ ■ ■	Gas	W2900*H1600mm
YSN-S26Q	W2600*H800mm	220mm	■ ■ ■ ■	Gas	W3500*H1600mm
YSN-S14D	W1400*H800mm	200mm	■ ■	Electricity	W2300*H1500mm
YSN-S20D	W2000*H800mm	200mm	■ ■ ■	Electricity	W2900*H1500mm
YSN-S26D	W2600*H800mm	200mm	■ ■ ■ ■	Electricity	W3500*H1500mm

隧道炉
Tunnel Oven



冷却塔
Cooling Tower

★接受非标定制
Accept non-standard
customization

