

HUADAO HUICHUANG(SHENZHEN)TECHNOLOGY CO.LTD

TEL:(0086)13724321459 CHINA ; (0092)3018454030 PAKISTAN

Email:Sales_1@yibotrd.com ; Sales_9@yibotrd.com;

Add:Building B,Zhengchangda Science and Technology Park,
Bao an District, Shenzhen

BAKERY EQUIPMENT



专业烘焙设备

HUADAO HUICHUANG(SHENZHEN)TECHNOLOGY CO.LTD

COMPANY PROFILE

公司介绍

让烘焙更轻松

HUADAO位于深圳市宝安区正昌达科技园 B 栋, 是一家领先的烘焙机械专业制造商。我们致力于提供涵盖产品研发、生产和销售的一站式综合服务, 满足各类面包店和面包工厂的多样化需求。

多年来, 我们打造了自己的知名品牌, 一直为国内外市场提供优质服务。我们的机器出口全球, 广受欢迎。秉持“质量第一”“客户至上”的基本原则, 我们致力于让每一位尊贵的客户都满意。

make bakery easy

HUADAO HUICHUANG(SHENZHEN)TECHNOLOGY CO.LTD, Located in Building B, Zhengchangda Science and Technology Park, Baoan District, Shenzhen, we are a leading professional manufacturer of bakery machines. Committed to providing a comprehensive one - stop service encompassing product research and development, production, and sales, we cater to the diverse needs of various bakeries and bread factories.

Over the years, we have cultivated our own renowned brands, which have been serving both domestic and international markets. Our machines are exported globally and have gained widespread popularity. Upholding the fundamental principles of “Quality Comes First” and “Customers Come First,” we are dedicated to ensuring the satisfaction of every valued customer.

食品加工设备解决方案 Food processing equipment solutions
@烘焙行业 Baking Industry

卓越品质

技术创新与人性化产品设计相结合, 用细节就卓越品质

安全效应

经多方面开发、测试、制造等, 并确保用户使用稳定及安全性

绿色发展

不断进行科技创新, 创造高品质的环保节能产品

经济效益

低能耗, 高效率, 从减少成本, 转换最大收益



我们有着严格的质量管理体系, 3C、CE、ISO9001 质量体系等认证



Mixing 搅拌类 05

Planetary Mixer/ Spiral Mixer
鲜奶机、打蛋机、和面机 05

Moulding 分块成型类 11

Manual Dough Divider / Electric Dough Divider / Hydraulic Dough Divider
手动分块机、电动分块机、液压分块机 11

Semi-Automatic Rounder / Continuous divider and rounder
半自动滚圆机、连续分块滚圆机 12

Pizza Roller
披萨压面机 13

Manual Pastry Sheeter / Automatic Pastry Sheeter
手动开酥机、全自动开酥机 14

Toast Moulder / Baguette Moulder
吐司成型机、法棒成型机 16

Fermentating 醒发类 17

Luxury Proofer / Fermentating Room Conditioner / Trolley Proofer Room
豪华型醒发箱、醒发室主机、推车式醒发房 17

Baking 烘烤类 19

Rotary Oven / luxury Deck Oven
热风旋转炉、豪华型层炉 19

Combination Oven/Convection Oven
组合炉、热风循环炉 21

Bread and cake forming products 面包蛋糕成型类 23

Toast Slicer / Cake Cutting Machine/Continuous Slicer / Cookie Machine/Filling Machine
吐司切片器、蛋糕切割器、连续切片器、曲奇机、注馅机 23

Baking Accessories 烘焙配件 25

Lifter
举缸器 25

Water Chiller/Blast Chiller
冷水机、速冻柜 26

Baking Tray/Cooling Net
烘焙烤盘、凉网 27

Stainless Steel Trolley/Work Table/Bread Basket
不锈钢台车架、工作台、面包筐 29



打蛋机系列 Planetary mixer

产品特点

- 1.整体压铸成型,全钢齿轮皮带传动。
- 2.低档到高档自由切换,无级别变速。
- 3.食用级 304 不锈钢搅拌组件,极佳不黏性。
- 4.巧妙结合行星公转与自转原理工具沿着容器边缘作自身运转:全方位搅拌。

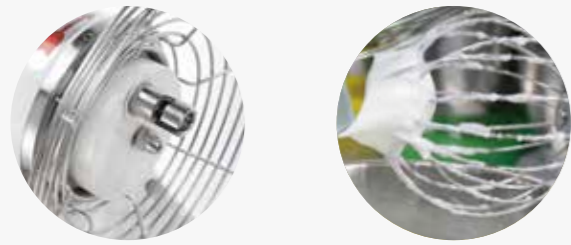

产品型号 Model	YB-5	YB-7
电压 Voltage	220V	220V
功率 Power	0.3Kw	0.35Kw
料桶容量 Bowl Volume	5L	7L
搅拌杆转速 Mixing Speed (r/min)	90/510	90/510
和面限量 Max.kneading Capacity	0.3Kg	0.4Kg
净重 Weight	12Kg	14.5Kg
外形尺寸 Dimensions	370*220*410mm	410*250*415mm



Features

- 1.Integral die-casting molding, all-steel gear belt drive
- 2.Free switching from low grade to high grade
- 3.Food grade 304 stainless steel Accessories assembly for excellent non-stick.
- 4.Combining the principles of planetary rotation, make blending more completely and evenly.

打蛋机系列 Planetary mixer



产品型号 Model	YB-10	YB-20	YB-30	YB-40
电压 Voltage	220V	220V	220V	220/380V
功率 Power	0.45Kw	0.75Kw	1.1Kw	1.5Kw
料桶容量 Bowl Volume	10L	20L	30L	40L
搅拌杆转速 Mixing Speed (r/min)	110/178/390	105/180/408	105/180/408	80/160/310
和面限量 Max.kneading Capacity	1Kg	3Kg	3.5Kg	4.5Kg
净重 Weight	56Kg	73Kg	90Kg	150Kg
外形尺寸 Dimensions	450*360*630mm	520*400*750mm	530*440*910mm	620*630*1010mm



打蛋机系列 Planetary mixer

产品特点

产品皮带传动,三档变速自由切换,多功能搅拌器满足各种搅拌需求。

Features

Belt drive, three-level variable speed can be switched freely to meet various mixing needs.



YI-10-20



YI-30-40-60



YI-80-100

Model	Voltage	Power	Bowl volume	Mixing speed (r/min)	Max.kneading capacity	Wight	Dimensions
产品型号	电压	功率	料桶容量	搅拌杆转速	和面限量	净重	外形尺寸
YI-10	220V	1HP	10L	110/178/355	1.5Kg	58Kg	450*432*680mm
YI-20	220/380V	1/2HP	20L	110/200/420	3Kg	82Kg	545*500*845mm
YI-30	220/380V	2HP	30L	80/160/388	4.5Kg	148Kg	630*562*1011mm
YI-40	220/380V	3HP	40L	80/160/388	6Kg	153Kg	645*562*1011mm
YI-60	380V	4HP	60L	74/155/388	8Kg	230Kg	768*625*1250mm
YI-80	380V	5.2Kw	80L	90/136/272	25Kg	480Kg	1208*807*1623mm
YI-100	380V	5.2Kw	100L	90/136/272	30Kg	580Kg	1208*807*1623mm

高速双球打蛋机 Industrial planetary mixer



产品型号 Model	YSN-S40L	YSN-S60L
电压 Voltage	380V	380V
功率 Power	1.5kw	3kw
料桶容量 Bowl Volume	40L	60L
搅拌公转速度 Stirring speed (r/min)	0-450	0-300
搅拌杆转速 Mixing speed (r/min)	0-700	0-450
净重 Weight	330Kg	465Kg
外形尺寸 Dimensions	750*700*1650mm	1000*1080*1770mm
包装尺寸 Package size	800*750*1850mm	1150*1150*1950mm



和面机系列 Spiral mixer



YSN-S60J



YSN-B60J

Model	Voltage	Power	Bowl Volume	Mixing Speed(r/min)	Max.kneading Capacity	Dimensions
产品型号	电压	功率/电机功率	料桶容量	搅拌杆转速	和面限量	外形尺寸
YSN-S20J	220V	1.5Kw	20L	150/200	8Kg	730*390*900mm
YSN-S30J	220V	1.5Kw	34L	150/200	12Kg	750*435*900mm
YSN-S40J	220/380V	3Kw	45L	150/200	16Kg	800*480*970mm
YSN-S50J	220/380V	3Kw	54L	150/200	20Kg	850*510*970mm
YSN-S60J	220/380V	3Kw	64L	150/200	25Kg	850*510*970mm
YSN-B20J	380V	0.45/0.75Kw	20L	207/103	8Kg	668*409*854mm
YSN-B30J	380V	0.85/1.5Kw	30L	207/103	12Kg	718*432*888mm
YSN-B40J	380V	1.5/2.4Kw	40L	220/110	16Kg	754*490*1033mm
YSN-B50J	380V	1.5/2.4Kw	50L	220/110	20Kg	794*520*1033mm
YSN-B60J	380V	1.5/2.4Kw	60L	216/108	25Kg	876*540*1120mm
YSN-B70J	380V	1.5/2.4Kw	70L	216/108	30Kg	920*580*1120mm

抬头式和面机 Head-up spiral mixer



YSN-20T (抬头式)

产品型号 Model	YSN-10T	YSN-20T	YSN-30T
电压 Voltage	220V	220V	220V
功率 Power	0.6kw	1.3kw	2kw
料桶容量 Bowl volume	10L	20L	30L
搅拌杆转速 Mixing speed (r/min)	90	90	90
料桶转速 Mixing speed (r/min)	9	9	9
和面限量 Max.kneading capacity	2kg	8kg	12kg
外形尺寸 Dimensions	576x312x586mm	695x395x630mm	810x445x715mm

高档款和面机 Luxury spiral mixer



产品特点

- 1.采用美国进口盖茨皮带, 耐力持久。
- 2.双速双动知名品牌电机, 提升至少40%的时间。
- 3.采用法国轴承, 搅拌无噪音, 耐磨。电子元件: 施耐德(法国)。

Features

1. Using Gates belt imported from the United States, it has long-lasting endurance.
2. Double-speed double-action well-known brand motor, improving the time by at least 40%.
3. Using French bearings, noise-free and wear-resistant. Electronic components: Schneider (France).



产品型号 Model	YSN-MJ25	YSN-MJ50	YSN-MJ75	YSN-MJ100	YSN-MJ125
电压 Voltage	220V/380V	380V	380V	380V	220V/380V
功率 Power	4.55Kw	6.55Kw	9.75Kw	12.75Kw	13.5Kw
料桶容量 Bowl volume	80L	130L	200L	250L	330L
和面限量 Max.kneading capacity	25Kg	50Kg	75Kg	100Kg	150Kg
搅拌杆转速 Mixing speed (Rpm)	125/245	110/230	106/225	106/225	106/225
净重 Weight	320Kg	430Kg	730Kg	760Kg	830Kg
外形尺寸 Dimensions	1080*630*1300mm	1150*700*1400mm	1450*860*1500mm	1450*860*1600mm	1520*970*1600mm

翻缸式和面机

Bowl tilting lift spiral mixer

产品特点

- 1.采用翻缸式设计倒出面团,省时省力。
- 2.整体设计采用超厚钣金焊接,美观耐用。
- 3.超大功率设计,进口元件,动力强劲,机械耐用度高。
- 4.电路具有过载保护功能,可避免因操作故障而损坏设备。
- 5.高效搅拌,面团吸水膨胀性高,节省生产成本。

Features

- 1.Using turn over bowl design to pour out the dough, saving time and effort.
- 2.The overall design adopts ultra-thick sheet metal welding,elegant and durable.
- 3.Super high-power design, imported component,with a strong power and high mechanical durability.
- 4.Circuit is provided with overload protection function, capable of avoid equipment damage due to operating failure.
- 5.High-efficiency mixing, high water absorption and expansion of dough, saving production costs.



产品型号 Model	YSN-75F	YSN-100F	YSN-125F	YSN-150F
电压 Voltage	380V	380V	380V	380V
功率 Power	12.1Kw	16.1Kw	19.5Kw	21Kw
翻起高度 Total height	1.8m	1.9m	1.99m	2m
和面限量 Max.kneading capacity	75Kg	100Kg	125Kg	150Kg
搅拌桶直径 Mixing bowl diameter	750mm	840mm	900mm	1000mm
外形尺寸 Dimensions	1466*1467*1415mm	1551*1608*1454mm	1600*1698*1521mm	1690*1708*1520mm

离缸式和面机

Bowl removable spiral mixer

产品特点

- 1.采用离缸式设计推出面团,方便周转。
- 2.机身采用不锈钢板材制作,易清洗,不生锈。
- 3.超大功率设计,进口元件,动力强劲,机械耐用度高。
- 4.电路具有过载保护功能,可避免因操作故障而损坏设备。
- 5.高效搅拌,面团吸水膨胀性高,节省生产成本。

Features

- 1.It adopts a bowl removable design to push out the dough, which facilitates turnover.
- 2.The body is made of stainless steel plate, which is easy to clean and does not rust.
- 3.Ultra-high power design, imported components, strong power and high mechanical durability.
- 4.The circuit has an overload protection function to avoid damage to the equipment due to operating failures.
- 5.Efficient mixing, the dough has high water absorption and expansion, saving production costs.



Model	Voltage	Power	Max.kneading capacity	Mixing speed	Drum speed	Soaring exterior dimensions	Drum size	Dimensions
产品型号	电压	功率	和面限量	搅拌杆转速 (rpm)	料桶转速 (rpm)	抬起外型尺寸	料桶尺寸	外型尺寸
YSN-L100	380V	17.6Kw	100kg	254/127	16	2040*1109*1789mm	840*500mm	1896*1109*1444mm
YSN-L125	380V	21Kw	125kg	228/114	16	2123*1207*1870mm	900*530mm	1976*1207*1446mm
YSN-L150	380V	21Kw	150kg	228/114	16	2145*1307*1870mm	900*530mm	2176*1307*1446mm

分块机

Dough divider

分块规格参考表 DIVISIONCHART		
Quantity 规格	Unit Weight 分块重量	Total Weight 面团总重量
9	112-336g 4-12oz	1008-3024g 36-108oz
18	56-168g 2-6oz	1008-3024g 36-108oz
36	28-84g 1-3oz	1008-3024g 36-108oz

* Specifications can be customized



YSN-SD9-18-36



YSN-FK9-18-36

Model	Voltage	Power	Standard	Dough weight	Weight	Dimensions
产品型号	电压	功率	规格	面团重量	净重	外形尺寸
YSN-SD36	/	/	36Pcs	30-120g	135Kg	530*440*1285mm
YSN-FK36	220/380V	0.75Kw	36Pcs	30-120g	160Kg	510*410*1280mm



液压分块机

Hydraulic dough divider

产品型号 Model	YSN-Y20
电压 Voltage	220/380V
功率 Power	1.5Kw
规格 Standard	20Pcs
面团重量 Dough weight	100-800g
净重 Weight	350kg
外形尺寸 Dimensions	610*680*1000mm

半自动分块滚圆机

Semi-automatic rounder

产品型号 Model	YSN-Q30	YSN-Q36
电压 Voltage	220/380V	220/380V
规格 Standard	30Pcs	36Pcs
面团重量 Dough weight	30-100g	20-80g
净重 Weight	320Kg	320Kg
外形尺寸 Dimensions	590*550*2100mm	590*550*2100mm



连续分块滚圆机

Continuous divider and rounder



YSN-K1P-2P-3P-4P

YSN-Y800

Model	Voltage	Power	Max capacity	Hopper volume	Weight range	Weight	Dimensions
产品型号	电压	功率	产能	料斗容量	重量范围	净重	外形尺寸
YSN-K1P	220/380V	1.5Kw	1900-7600 Pcs/h	30-100kg	10-500g	480Kg	880*1200*1500mm
YSN-Y800	220/380V	0.4Kw	1900-7600 Pcs/h	/	10-500g	380Kg	850*850*1450mm



披萨压面机 Pizza roller



YNS-P30



YNS-P40

Model	Voltage	Power	Pizza diameter	Dough weight	Weight	Dimensions
产品型号	电压	功率	披萨直径	面团重量	净重	外形尺寸
YNS-P30	220V	0.37kw	100-300mm	50-500g	37kg	530*480*560mm
YNS-P40	220V	0.37kw	100-400mm	50-500g	39kg	530*530*650mm

链式披萨炉 Chain pizza oven



产品型号 Model	YNS-P15D	YNS-P15Q
电压 Voltage	220V/380V	220V
功率 Power	9kW	0.1kW
能源 Energy	电力型 Electric	燃气型 Gas
链条尺寸 Chain size	1215*400mm	1215*400mm
进炉高度 Height of entrance	80mm	80mm
净重 Weight	120kg	135kg
外形尺寸 Dimensions	1450*975*450mm	1450*975*450mm



链式披萨炉
Chain Pizza Oven

开酥机系列 Pastry sheeter

产品特点

- 1.进口输送带, 不起毛, 耐磨性强
- 2.进口电机, 使用寿命长
- 3.整机结构坚固, 稳定性强, 折叠式设计, 节省空间

Features

1. Imported conveyor belt, lint-free, strong wear resistance
2. Imported motor, long service life
3. The whole machine has a solid structure, strong stability, and foldable design to save space.



YNS-520T



台式开酥机
Table Dough Sheeter



YNS-520L



YNS-520L
自动撒粉 Automatic flour spreading



立式开酥机
Stand dough sheeter

产品型号 Model	YNS-420T	YNS-520T	YNS-450L	YNS-520L	YNS-650L
电压 Voltage	220/380V	220/380V	220/380V	220/380V	220/380V
功率 Power	0.55Kw	0.55Kw	0.55Kw	0.55Kw	0.75Kw
压辊范围 Roller range	0.5-38mm	0.5-38mm	0.5-38mm	0.5-38mm	0.5-38mm
输送带尺寸 Conveyor size	430*1700mm	500*2160mm	430*1700mm	500*2160mm	630*2160mm
面团限量 Max.dough weight	4Kg	5Kg	4Kg	5Kg	6.5Kg
折叠尺寸 Folding size	930*750*860mm	950*750*1080mm	900*680*1350mm	930*680*1570mm	1065*680*1690mm
净重 Weight	120Kg	160Kg	180Kg	190Kg	230Kg
外形尺寸 Dimensions	1770*810*640mm	2230*880*640mm	1780*900*1060mm	2150*950*1050mm	2390*1080*1050mm

全自动开酥机 Automatic pastry sheeter

产品特点

1. 全自动设计, PLC控制面板, 可保存多组配方记忆数据。操作更简单方便, 效率更高。
2. 自动调节压面的厚度, 比人工操作更精准。最薄可均匀滚压至1mm。
3. 全不锈钢材质, 配置自动撒粉和自动卷面装置。
4. 可根据客户要求定制不同大小和使用不同材料。



YSN-650BZ
自动压面
Automatic dough pressing

Features

1. Fully automatic design, PLC control panel, can save multiple sets of formula memory data. The operation is simpler and more convenient, and the efficiency is higher.
2. Automatically adjust the thickness of the pressing surface, which is more accurate than manual operation. The thinnest can be rolled evenly to 1mm.
3. Made entirely of stainless steel, equipped with automatic flour spreading and automatic dough rolling devices.
4. Different sizes and materials can be customized according to customer requirements.



YSN-650ZDA
自动压面、撒粉、卷面
Automatic dough pressing \Flour spraying\Roll up function

Model	Voltage	Power	Max.dough weight	Roller range	Conveyor size	Weight	Dimensions
产品型号	电压	功率	面团限量	压辊范围	传送带尺寸	净重	外形尺寸
YSN-650ZDA	380V	1.5kw	15kg	0.5-50mm	4000*630mm	550kg	4080*1135*1330mm
YSN-650BZ	380V	1.5kw	15kg	0.5-50mm	4000*630mm	380kg	3750*1135*1210mm

吐司整形机 Toast moulder



YSN-T380



YSN-280Z

Model	Voltage	Power	Standard	Weight	Dimensions
产品型号	电压	功率	规格	净重	外形尺寸
YSN-T380	220V	0.75Kw	38cm	190Kg	1400*670*1120mm
YSN-280Z	220/380V	0.37Kw	10-1500g	145Kg	1000*530*1060mm

法棒整形机 Baguette moulder

产品特点

1. 食品级滚轴, 超大进料口, 高效省力。
2. 法国进口羊毛传输带, 质量上乘。
3. 机身采用钢板材质, 坚固耐用。

Features

1. Food-grade rollers, extra-large dough inlet, efficient and labor-saving.
2. Wool conveyor belt imported from France, high quality.
3. The body is made of steel plate, which is strong and durable.



产品型号 Model	YSN-F750
电压 Voltage	220/380V
功率 Power	0.75Kw
规格 Standard	50-1250g
净重 Weight	285Kg
外形尺寸 Dimensions	960*1010*1600mm

豪华型醒发箱 Luxury proofer



YSN-L36D



YSN-L36SS



YSN-L36SX

Model	Voltage	Power	Temperature	Capacity	Tray size	Dimensions
产品型号	电压	功率	温度	容量	烤盘尺寸	外形尺寸
YSN-F18	220V	2.3Kw	15~38°C	18盘	400*600mm	570*815*2000mm
YSN-L18D	220V	1.5Kw	2~5°C	18盘	400*600mm	930*610*2060mm
YSN-L36D	220V	2.6Kw	2~5°C	36盘	400*600mm	812*1134*2060mm
YSN-L36SX	220V	6Kw	-15°C/2~5°C	36盘	400*600mm	810*1240*2200mm
YSN-L36SS	220V	6Kw	-15°C/2~5°C	36盘	400*600mm	940*1250*2060mm

醒发室主机

Fermentating Room Conditioner

产品型号 Model	YSN-T8
电压 Voltage	220/380V
功率 Power	10.5Kw
醒发温度范围 Temperature	15~38°C
容量 Capacity	8 Trolley
净重 Weight	65Kg
外形尺寸 Dimensions	1100*320*1510mm



推车式醒发房 Trolley proofer room



产品特点

采用创新专利技术,具有自动进水功能。设备采用干式发热管加温,湿式发热管加湿,通过控制电路,使醒发箱内产生相对湿度80-85%、温度36°C~38°C的适宜发酵环境,帮助整形后的面包胚完成发酵过程。

Features

It adopts innovative patented technology with automatic water inflow function. The equipment uses dry heating tubes for heating and wet heating tubes for humidification. Through controlling circuit, create a suitable fermentation environment with a relative humidity of 80-85% and a temperature of 36°C~38°C to help complete the fermentation of the dough which have completed moulding.



产品名称 Product name	单门 Single door	双门 Double door
电压 Voltage	220/380V	220/380V
能源 Energy	电力、燃气/Electric、Gas	电力、燃气/Electric、Gas
冷藏温度 Refrigeration	2~5°C/15-50°C	2~5°C/15-50°C
醒发温度范围 Temperature	15~38°C	15~38°C
房板厚度 Panel thickness	100mm	100mm
容量 Capacity	1-8 Trolley	1-8 Trolley
按需求定制 Can be customized	机身材质、门、功能、面板/Material、doors、functions、panels	

热风旋转炉

Rotary oven



YSN-12EZ

产品特点

广泛用于烘烤月饼、面包、糕点、零食、饼干等。烘烤量大，节省人力，一次可烘烤32/64盘，适用于中型以上面包店、工厂。日本/意大利进口燃烧器，多道送风口，穿透力强，烘烤效果更佳。经20年测试，性能稳定、高效率、低能耗。



YSN-32G

Features

Widely used in baking moon cakes, bread, cakes, snacks, biscuits etc. It has a large baking capacity and saves manpower which can bake 32/64 trays at one time. It is suitable for medium-sized and above bakeries and factories. Burner imported from Japan/Italy, with multiple air outlets, strong penetration and better baking effect. After 20 years of testing, it has stable performance, high efficiency and low energy consumption.

Model	Voltage	Power	Energy	Capacity	Tray size	Dimensions
产品型号	电压	功率	能源	容量	烤盘尺寸	外形尺寸
YSN-12EZ	380v	24kw	电力 Electric	12盘	400*600mm	1950*1350*2100mm
YSN-12GZ	380v	1.4kw	燃气 Gas	12盘	400*600mm	1950*1350*2100mm
YSN-12DZ	380v	1.4kw	柴油 Diesel	12盘	400*600mm	1950*1350*2100mm
YL-32E	380v	59Kw	电力 Electric	32盘	400*600mm	2680*1680*2450mm
YL-32G	380v	3.5Kw	燃气 Gas	32盘	400*600mm	2680*1800*2450mm
YL-32D	380v	3.5Kw	柴油 Diesel	32盘	400*600mm	2680*1800*2450mm
YL-64E	380v	72Kw	电力 Electric	64盘	400*600mm	3200*2100*2450mm
YL-64G	380v	4.5Kw	燃气 Gas	64盘	400*600mm	3200*2250*2450mm
YL-64D	380v	4.5Kw	柴油 Diesel	64盘	400*600mm	3200*2250*2450mm

电热层炉

Electric deck oven



产品特点

1. 双层防爆玻璃视窗，内置耐高温照明灯，手动面板和智能电脑控制面板可选，操控简便。
2. 采用高质量电器元件，精度高，品质好。
3. 层炉可拆卸，每层可独立工作。

Features

1. Double-layer explosion-proof glass window, built-in high-temperature-resistant lighting, manual panel and intelligent computer control panel optional, easy to operate.
2. Use high-quality electrical components with high precision and good quality.
3. The oven is detachable and each layer can work independently.

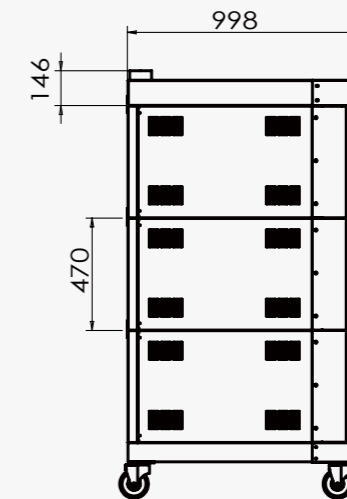
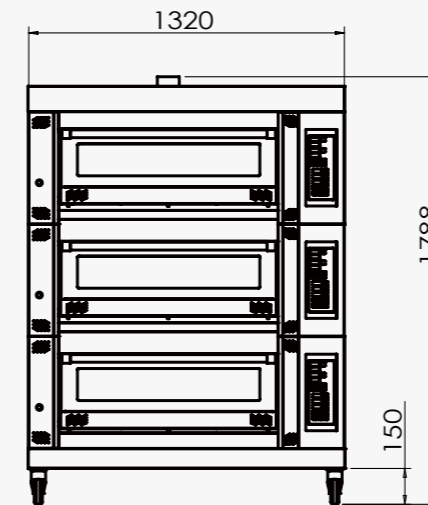

Model	Voltage	Power	Capacity	Tray size	Weight	Dimensions
产品型号	电压	功率	容量	烤盘尺寸	净重	外形尺寸
YSN-102D	380v	6.5kw	1层2盘 1 deck 2 trays	400*600mm	145kg	1323*998*803mm
YSN-204D	380v	13kw	2层4盘 2 deck 4 trays	400*600mm	290kg	1323*998*1319mm
YSN-306D	380v	19.5kw	3层6盘 3 deck 6 trays	400*600mm	435kg	1323*998*1789mm
YSN-309D	380v	25.5kw	3层9盘 3 deck 9 trays	400*600mm	585kg	1748*998*1789mm

燃气型层炉

Gas deck oven



1层2盘
1 deck 2 trays

2层4盘
2 deck 4 trays

3层6盘
3 deck 6 trays

Model	Voltage	Power	Capacity	Tray size	Weight	Dimensions
产品型号	电压	功率	容量	烤盘尺寸	净重	外形尺寸
YSN-102Q	220/380v	0.1kw	1层2盘 1 deck 2 trays	400*600mm	185kg	1322*1063*823mm
YSN-204Q	220/380v	0.2kw	2层4盘 2 deck 4 trays	400*600mm	370kg	1322*1063*1432mm
YSN-306Q	220/380v	0.3kw	3层6盘 3 deck 6 trays	400*600mm	555kg	1322*1063*1952mm
YSN-309Q	220/380v	0.3kw	3层9盘 3 deck 9 trays	400*600mm	830kg	1747*1063*1985mm

多功能组合炉

Multi-functional combination oven

型号 Model	YSN-204-5E	YSN-204-10P
电压 Voltage	380V	380V
功率 Power	20.5kw	15kw
烘烤容量 Baking Capacity	2层4盘	2层4盘
组合容量 Combined capacity	5盘	10盘/醒发
烤盘尺寸 Trays size	400*600mm	400*600mm
净重 Weight	480kg	490kg
外形尺寸 Dimensions	1335*1322*2098mm	1335*1322*2040mm



YSN-204-5E

热风循环炉

Convection oven

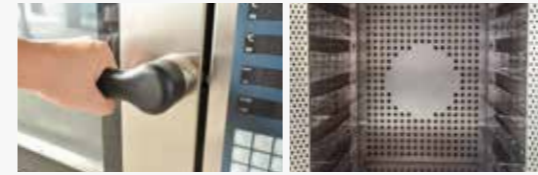

YSN-5D



YSN-10D

产品型号 Model	YSN-5D	YSN-10D	YSN-5Q
电压 Voltage	220/380V	220/380V	220V
功率 Power	7.5Kw	15Kw	0.5Kw
能源方式 Energy mode	电力 Electric	电力 Electric	燃气 Gas
容量 Capacity	5盘	10盘	5盘
烤盘尺寸 Tray size	400x600mm	400x600mm	400x600mm
净重 Weight	168Kg	205Kg	230Kg
外形尺寸 Dimensions	1284*800*742mm	1284*800*1665mm	1284*800*1802mm

热风炉

Convection oven

型号 Model	YSN-4A
电压 Voltage	220V
功率 Power	4.6kw
容量 Capacity	8 trays
外形尺寸 Dimensions	670*640*500mm



YSN-4A-6A

面包切片机 Toast slicer

产品型号 Model	YSN-Q31
电压 Voltage	220V
功率 Power	0.25Kw
刀片数量 Number of slice	31pcs
重量 Weight	65Kg
外形尺寸 Dimensions	650*740*780mm



蛋糕水平切割机 Cake cutting machine

产品型号 Model	YSN-303B
电压 Voltage	220V
功率 Power	1.5Kw
额定频率 Frequency	50Hz
净重 Capacity	280Kg
外形尺寸 Dimensions	1320*820*1200mm



连续切片机 Continuous slicer

产品型号 Model	YSN-Q60
电压 Voltage	220V
功率 Power	1.2Kw
速度 Velocity	1200pcs/h
净重 Weight	200KG
外形尺寸 Dimensions	2200*650*1300mm



曲奇机 Cookie machine

产品特点

- 1.制作各种花式曲奇、西饼、泡芙、马卡龙等。
- 2.采用日本三菱PLC控制器和液晶触摸屏,且具有配方记忆功能,操作便捷。
- 3.食品级压面滚轴和成型料嘴,安全卫生。不粘面输送带,输送顺畅不跑偏不粘连。
- 4.一机多用,可定制花嘴,出品均匀稳定,适合小量多样和批量生产。

Features

1. Make various fancy cookies, pastries, puffs, macarons, etc.
2. It adopts Japanese Mitsubishi PLC controller and LCD touch screen, has recipe memory function, making it easy to operate.
3. Food-grade pressing roller and molding nozzle, safe and hygienic. non-stick conveyor belt, smooth transportation without deviation or adhesion.
4. Multiple function, the spout can be customized, and the output is uniform and stable, suitable for small-capacity but diverse and mass production.



产品型号 Model	YSN-102
电压 Voltage	220V
功率 Power	1.5Kw
频率 Frequency	50Hz
产量 Production	60~100Kg/H
净重 Capacity	400Kg
外形尺寸 Dimensions	1600*950*1400mm

注馅机 Filling machine

产品型号	YSN-001
电压 Voltage	220V
功率 Power	0.4Kw
速度 Capacity	300-400pcs/h
净重 Weight	50KG
外形尺寸 Dimensions	470*580*750mm

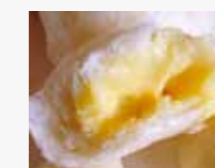

举缸器系列

Lifter

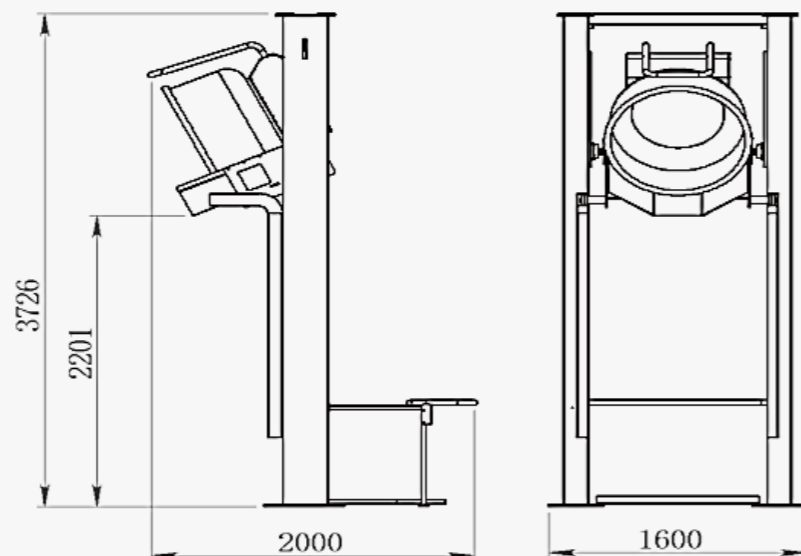

和面机举缸器
YSN-HT2200



打蛋机举缸器 YSN-DT1450

Model	Power	Voltage	Lift height	Weight	Dimensions
产品型号	功率	电压	提升高度	净重	外形尺寸
YSN-HT2200	2.2Kw	380V	2200mm	750kg	3726*2000*1600mm
YSN-DT1450	0.55Kw	380V	1450mm	250kg	1400*1510*2230mm

连续冷水机

Continuous water chiller

产品型号 Model	YSN-5A
电压 Voltage	220V±10%
功率 Power	5.85Kw
制冷量 Cooling capacity	11607/Kcal/h
最大流量 Maximum flow rate	50L/min
制冷剂 Refrigerant	R22
外形尺寸 Dimensions	1100*600*960mm



推车速冻柜

Trolley Blast chiller



YSN-15T40C



YSN-30T40C

Model	Supply	Power	Temperature	Refrigerant type	Door	Refrigerant	Dimensions
产品型号	电源	功率	温度范围	制冷方式	门数	制冷剂	外形尺寸
YSN-15T40	380V/32A	3kw	-40-0°C	风冷	1	R404a	1050*940*2200mm
YSN-30T40	380V/32A	6kw	-40-0°C	风冷	2	R404a	1900*940*2200mm
YSN-15T40C	380V/32A	5.2kw	-40-0°C	风冷	1	R404a	1600*1050*1980mm
YSN-30T40C	380V/32A	6.8kw	-40-0°C	风冷	2	R404a	1865*1150*1980mm

烤盘系列

Baking trays



机冲烤盘(素面)
Stamping baking trays



机冲烤盘(冲孔)
stamping perforated trays



机冲烤盘(不沾)
stamping perforated baking trays (Non-stick)

Model	Material	Oty of package	Tray size	Pan depth
产品型号	材质	包装规格	烤盘尺寸	烤盘深度
YSN-8001	铝合金 Aluminum alloy	25Pcs	400*600mm	30/50mm
YSN-8002	铝合金 Aluminum alloy	25Pcs	400*600mm	30/50mm



铝合金法式烤盘(不沾)
Aluminum alloy baguette trays (Non-stick)



不锈钢边法式烤盘(不沾)
Stainless steel frame baguette trays(Non-stick)



铝边法式烤盘
Aluminum alloy frame baguette trays (Non-stick)

Model	Material	Number of rows	Oty of package	Pan depth	Tray size
产品型号	材质	槽数	包装规格	烤盘深度	烤盘尺寸
YSN-8009	0.8/1.0mm Aluminum	5/6	10Pcs	30mm	400*600/460*660/460*720mm
YSN-8010	0.8/1mm 铝合金 Aluminum	5/6	10Pcs	30mm	400*600/460*660/460*720mm
YSN-8011	1mm 铝合金 Aluminum	7/8/9/10	10Pcs	30mm	400*600/600*800/800*1000mm



波纹吐司盒(不沾)
Toast box (Non-stick)

Capacity	Upsize	Bottom size	Height
容量	上尺寸	下尺寸	高度
250g	164*94mm	158*87mm	77mm
450g	197*106mm	186*101mm	110mm
750g	316*100mm	305*93mm	116mm
1200g	164*94mm	361*116mm	125mm



披萨烤盘(不沾)
Pizza baking tray (Non-stick)

Model	Diameter	Bottom	Height	Weight
产品型号	直径	底部	高度	重量
YSN-230	23.4cm	21cm	2cm	248g
YSN-260	26cm	23.7cm	2cm	278g
YSN-290	29cm	27cm	2cm	367g
YSN-310	31.9cm	29cm	2cm	427g



15连汉堡烤盘(镀铝板)
Hamburger Roll trays-15(Alusteel)



24 连圆模(镀铝板)
Roll trays-24(Alusteel)

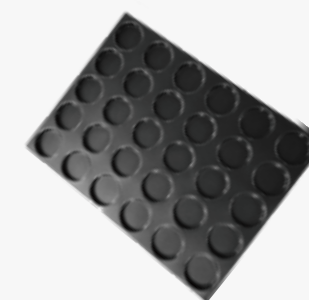

30 连圆模(镀铝板)
Roll trays-35(Alusteel)

产品型号 Model	YSN-8012	YSN-8013	YSN-8014
材质 Material	Alusteel	Alusteel	Alusteel
模具数量 Number of holes	15	24	30
烤盘尺寸 Tray size	400*600*40mm	400*600*40mm	400*600*40mm
厚度 Thickness	0.8mm	0.4/0.8mm	0.4/0.8mm



YSN-8018

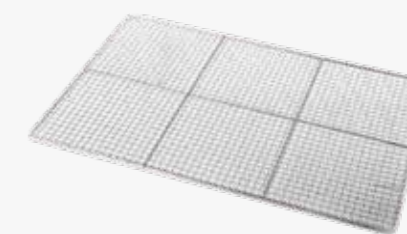

YSN-8019

Model	Name	Material	Size
产品型号	名称	材质	尺寸
YSN-8018	凉网 Cooling net	201/304 Stainless steel	400*600mm
YSN-8019	凉网 Cooling net	201/304 Stainless steel	400*600mm

不锈钢台车架

Stainless steel trolley

产品特点

- 1.全车采用不锈钢焊接工艺,坚固耐用。螺丝安装,组装方便。
- 2.车架配有定位杆,可以起到很好的固定作用。
- 3.脚轮采用耐高温万向轮,可耐高温最高达280°C,移动方便。



Features

- 1.The whole trolley adopts stainless steel welding process, strong and durable. Screw installation, easy to assemble.
- 2.The frame is equipped with positioning rods, which can play a good fixing role.
- 3.The casters adopt high-temperature resistant universal wheels, which can withstand high temperatures up to 280°C and are easy to move.



YSN-16T



YSN-32T

Model	Material	Capacity	Type	Weight	Trays size	Dimensions
产品型号	材质	容量	类型	重量	烤盘尺寸	外形尺寸
YSN-16T	201/304SUS	16盘	烘焙车	28kg	400*600mm	610*470*1750mm
YSN-32T	201/304SUS	32盘	烘焙车	39kg	400*600mm	810*670*1750mm

不锈钢工作台

Stainless steel work table



单层无背
1-Tier work table



单层有背
1-Tier work table with backsplash



双层无背
2-Tier work table



双层有背
2-Tier work table with backsplash

Model	Dimensions
产品型号	外形尺寸
YSN-081	800*700*850mm
YSN-121	1200*700*850mm
YSN-181	1800*700*850mm
YSN-201	2000*700*850mm

Model	Dimensions
产品型号	外形尺寸
YSN-082	800*700*850mm
YSN-122	1200*700*850mm
YSN-182	1800*700*850mm
YSN-202	2000*700*850mm

面包框

Bread basket

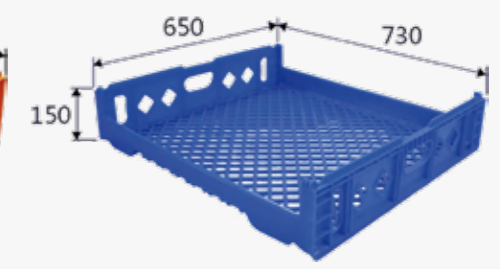
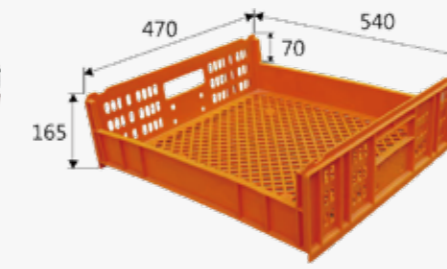
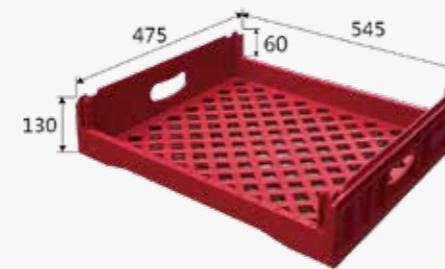
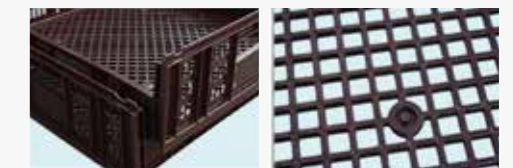

产品型号 Model	YSN-6480	YSN-6485	YSN-6647	YSN-6650
重量 Weight	1.4kg	1.22kg	2.32kg	2.33kg
外形尺寸 Dimensions	550*480*165mm	550*485*126mm	716*647*150mm	725*650*150mm